

MD291_04

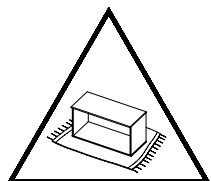

← 320 cm →

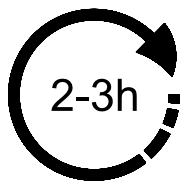
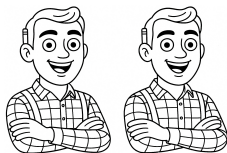
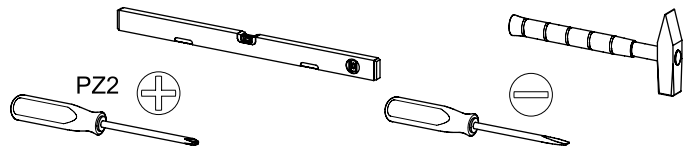
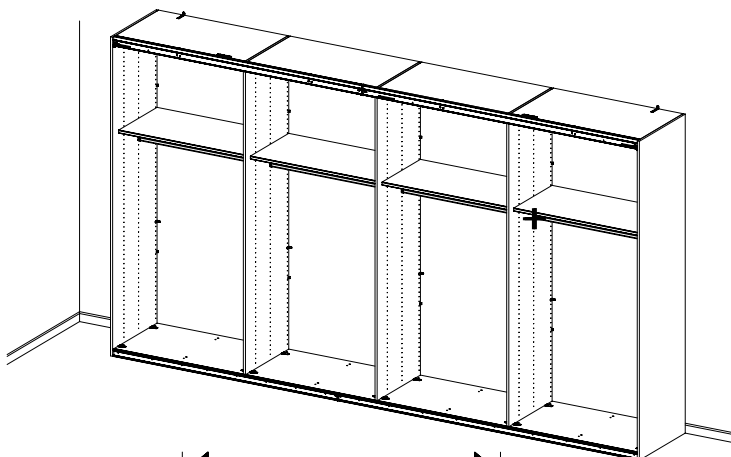
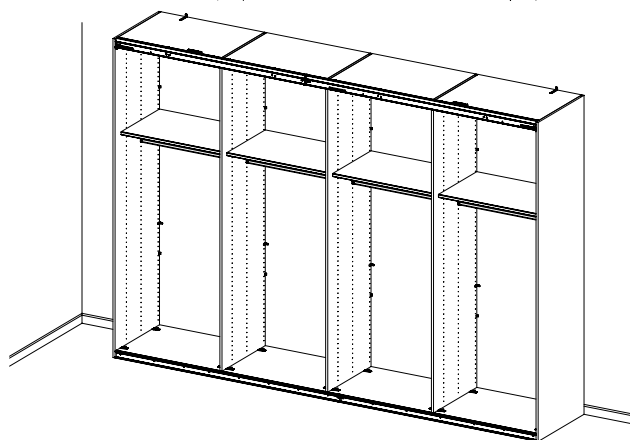

← 400 cm →

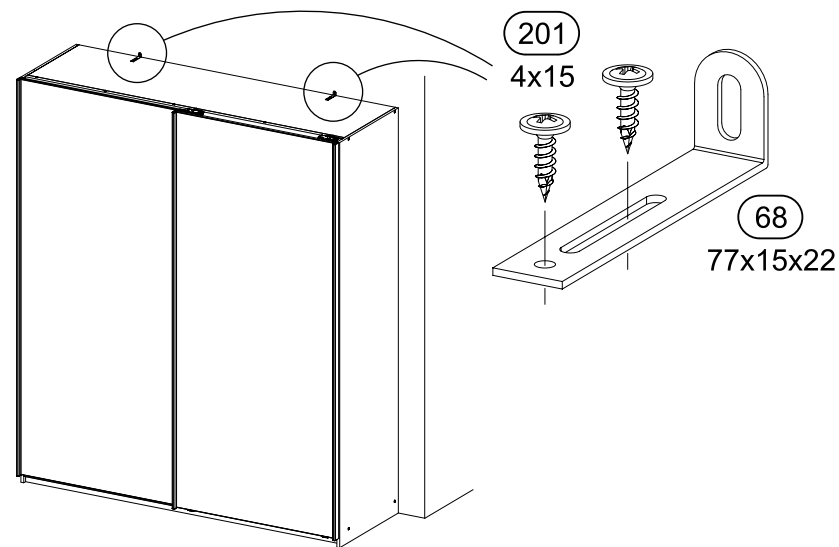
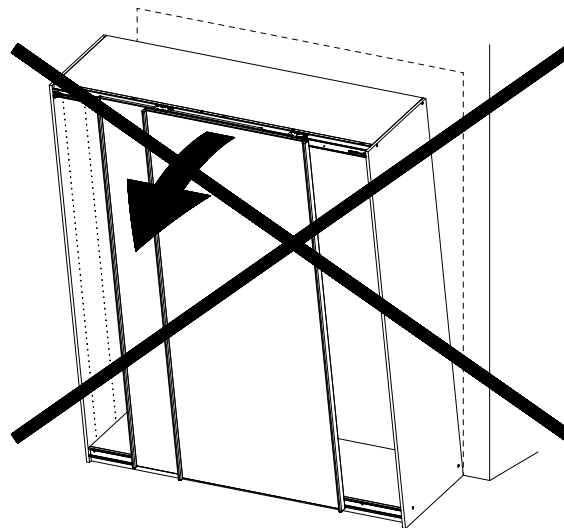

VIDEO







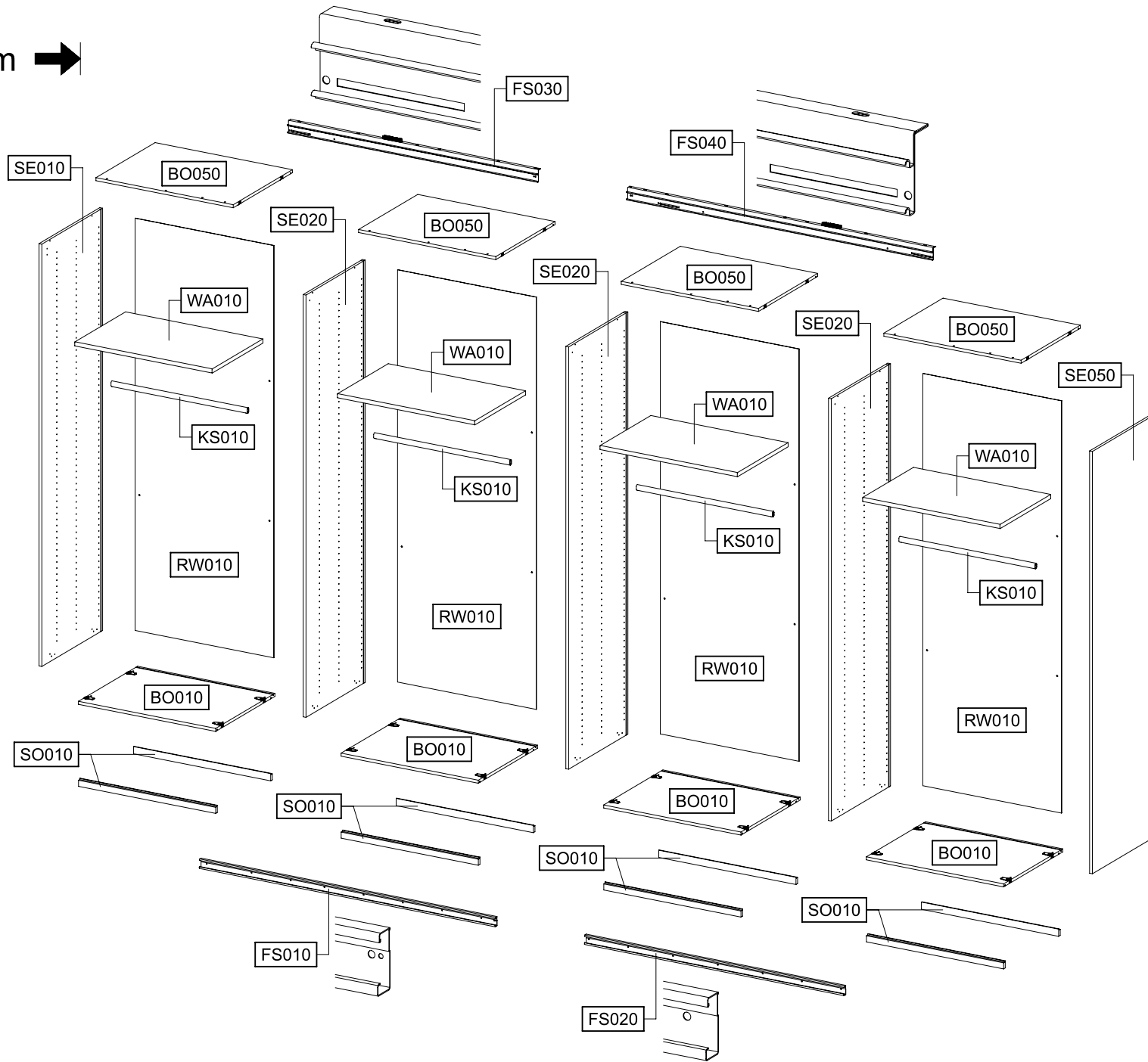

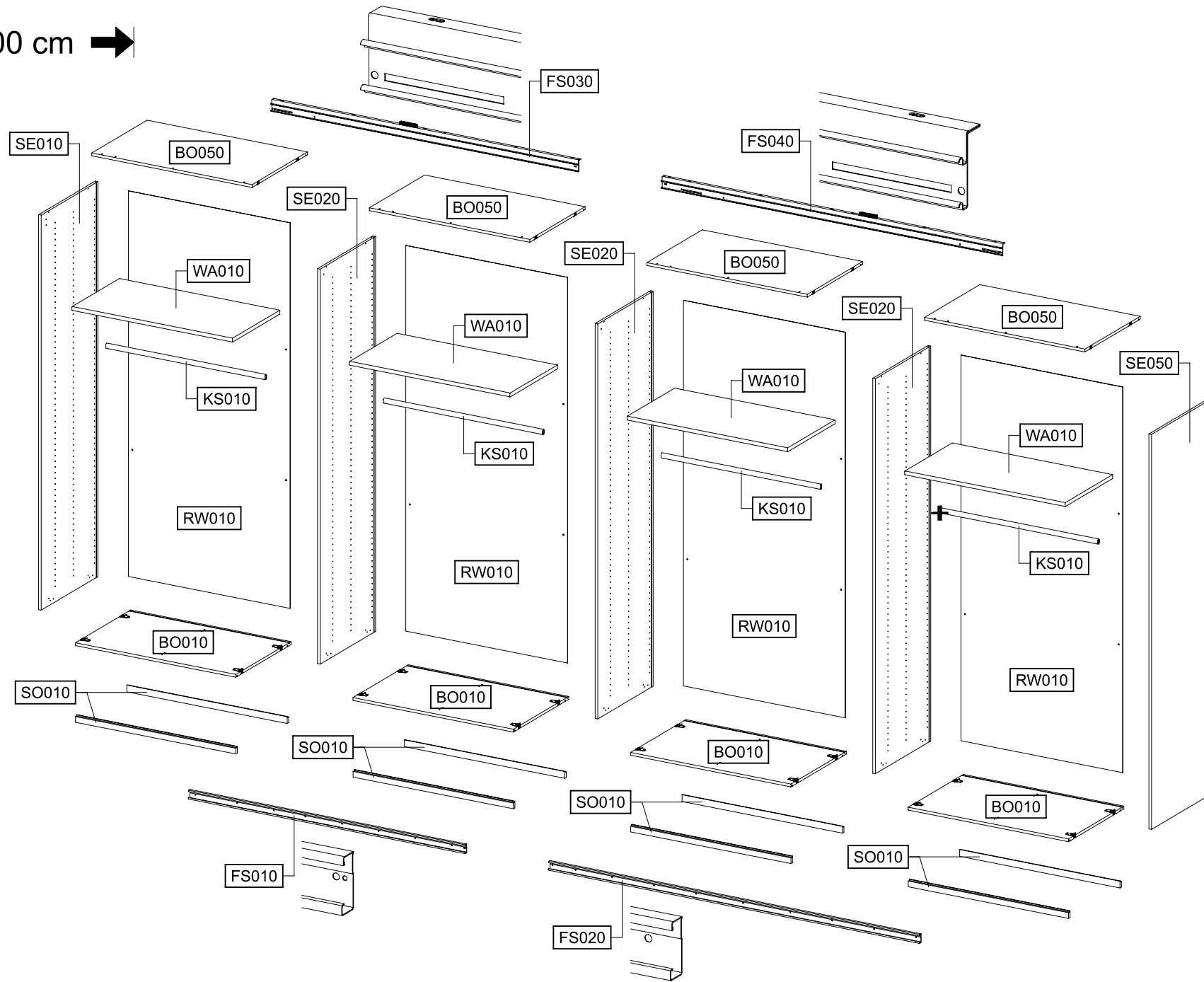

SCAN ME

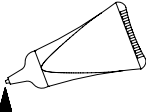
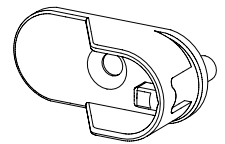
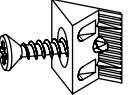
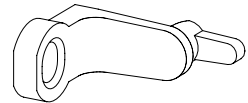
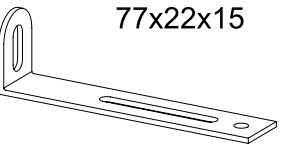
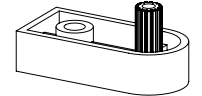



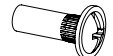

← 320 cm →

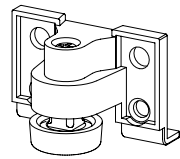
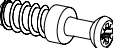
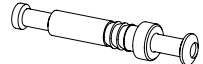

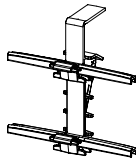
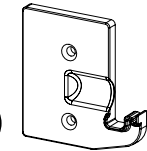
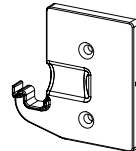
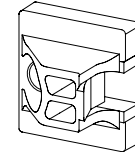
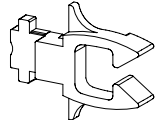
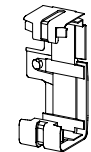
← 400 cm →

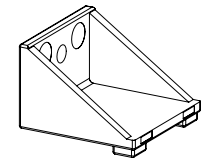

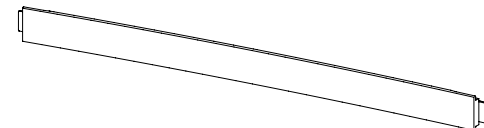
4x  11	8x  29
16x  45	16x  47
2x  77x22x15 68	1x  31,8x15x8 133
36x  4x15 201	29-32x  3,5x15 205
13x  M4x12 211	0-8x  Ø5 375
32x  6x8 534	13x  M4 580
16x  6,5x12 779	16x  974
8x  1085	12x  1086

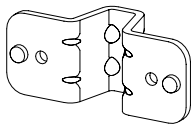
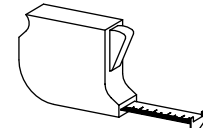
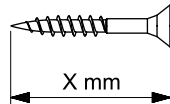
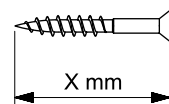
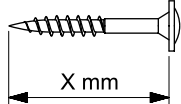
16x  1089	1x  1163
1x  1165	1x  1166
2x  1167	2x  1168
1x  1169	16-24x  Ø8 405
4x  1277	2x  M5x12 1279
2x  1280	2x  M5 1288
2x  M5x8 1449	1x  1450
	 X mm
	 X mm
	 X mm

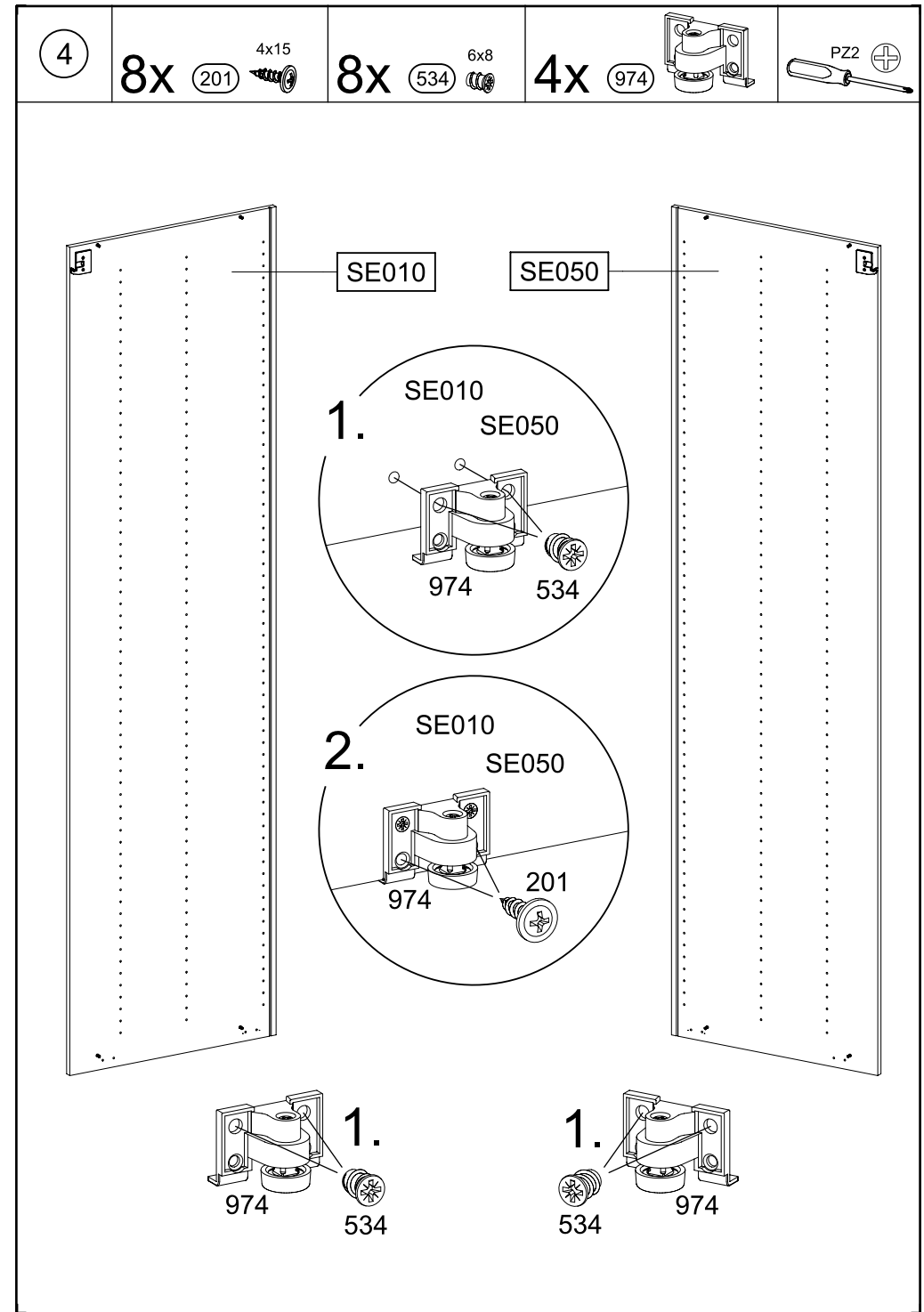
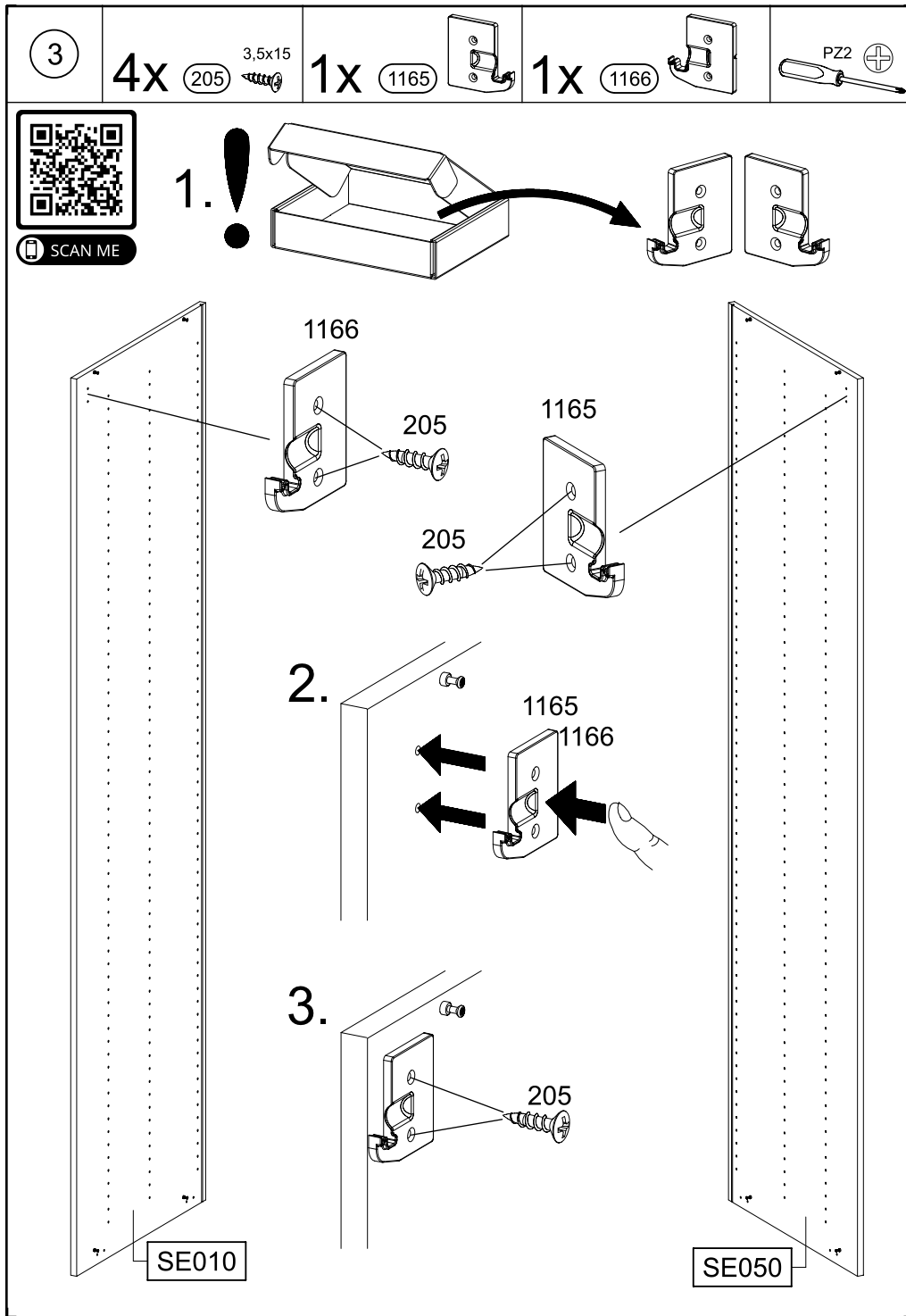

5

12x 1086

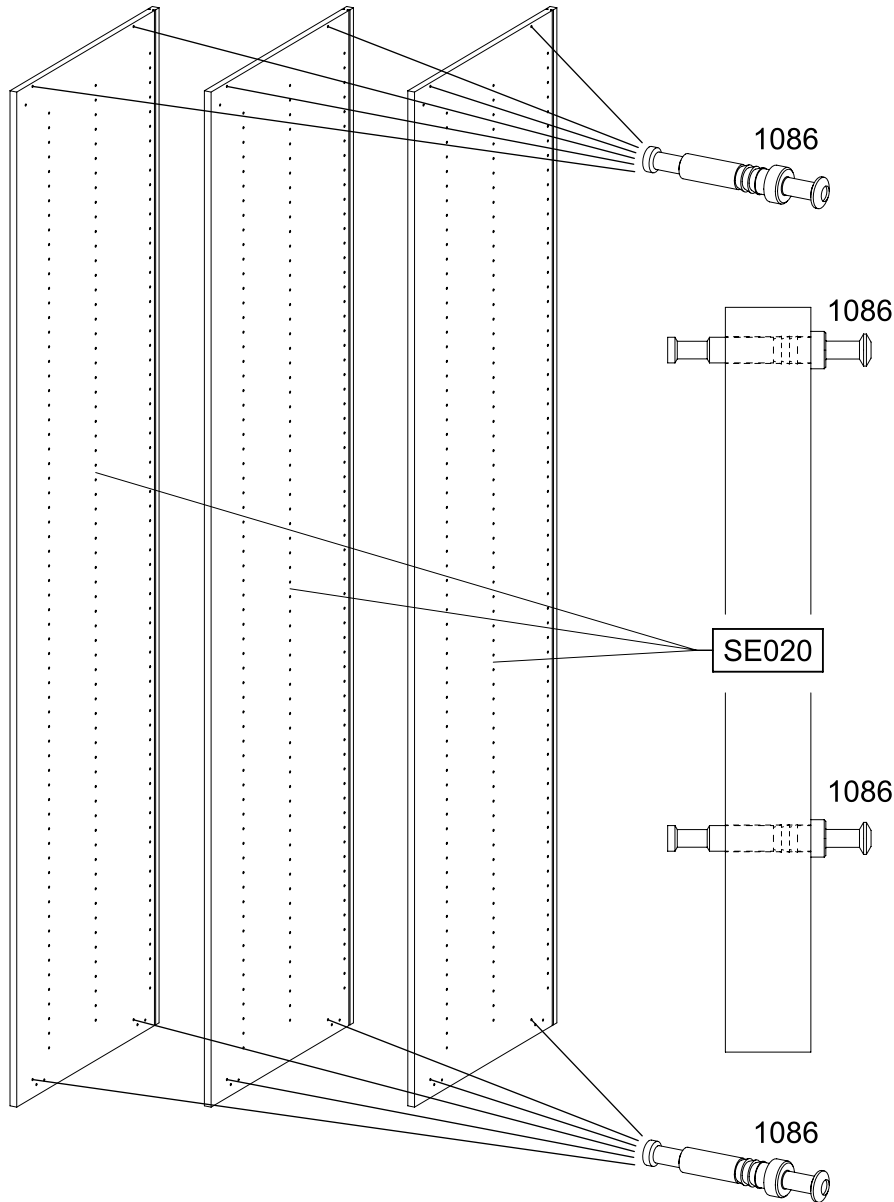
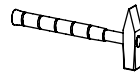
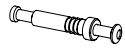

6

24x 201

4x15

24x 534

6x8

12x 974

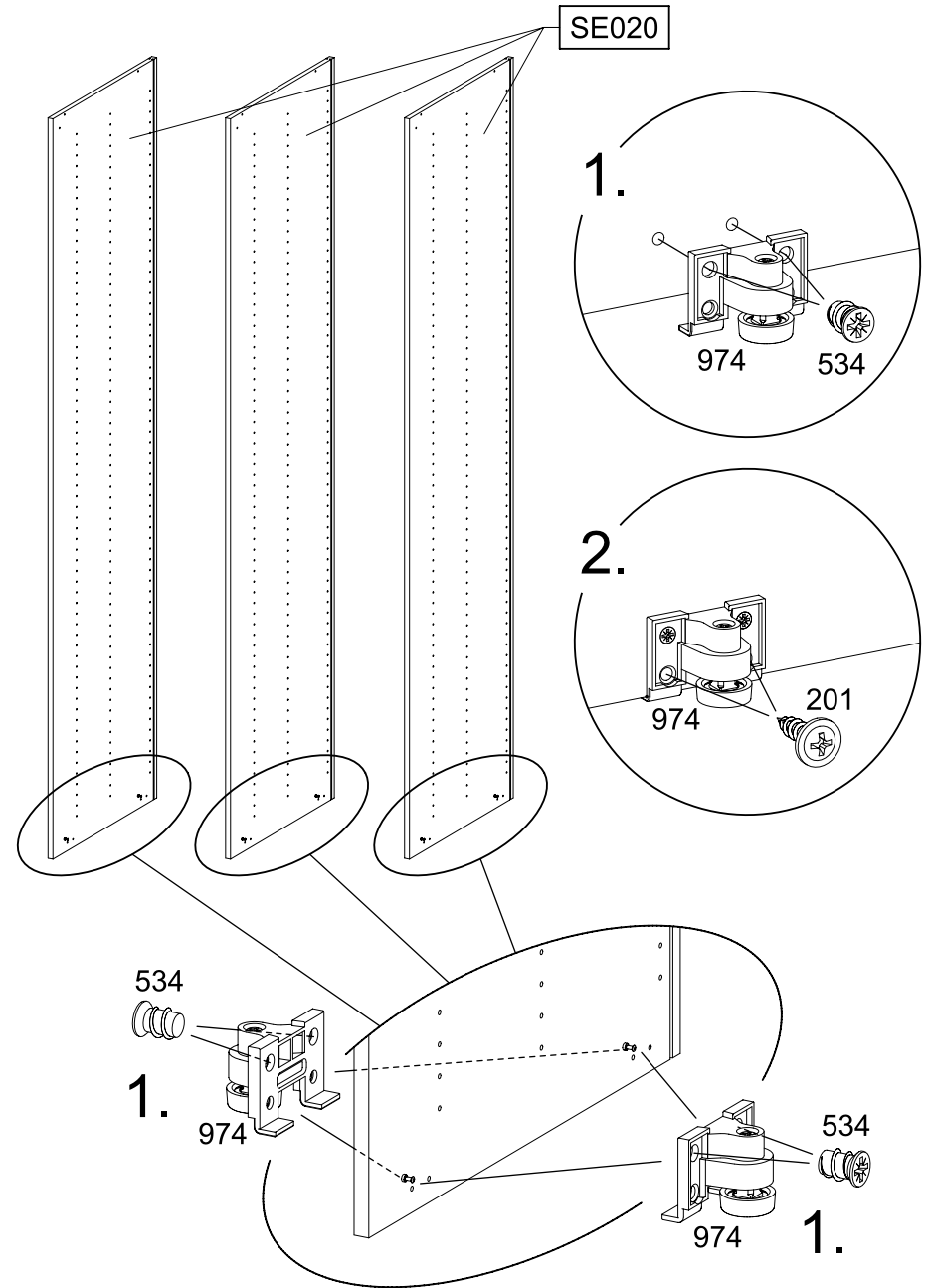
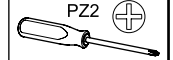
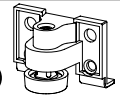

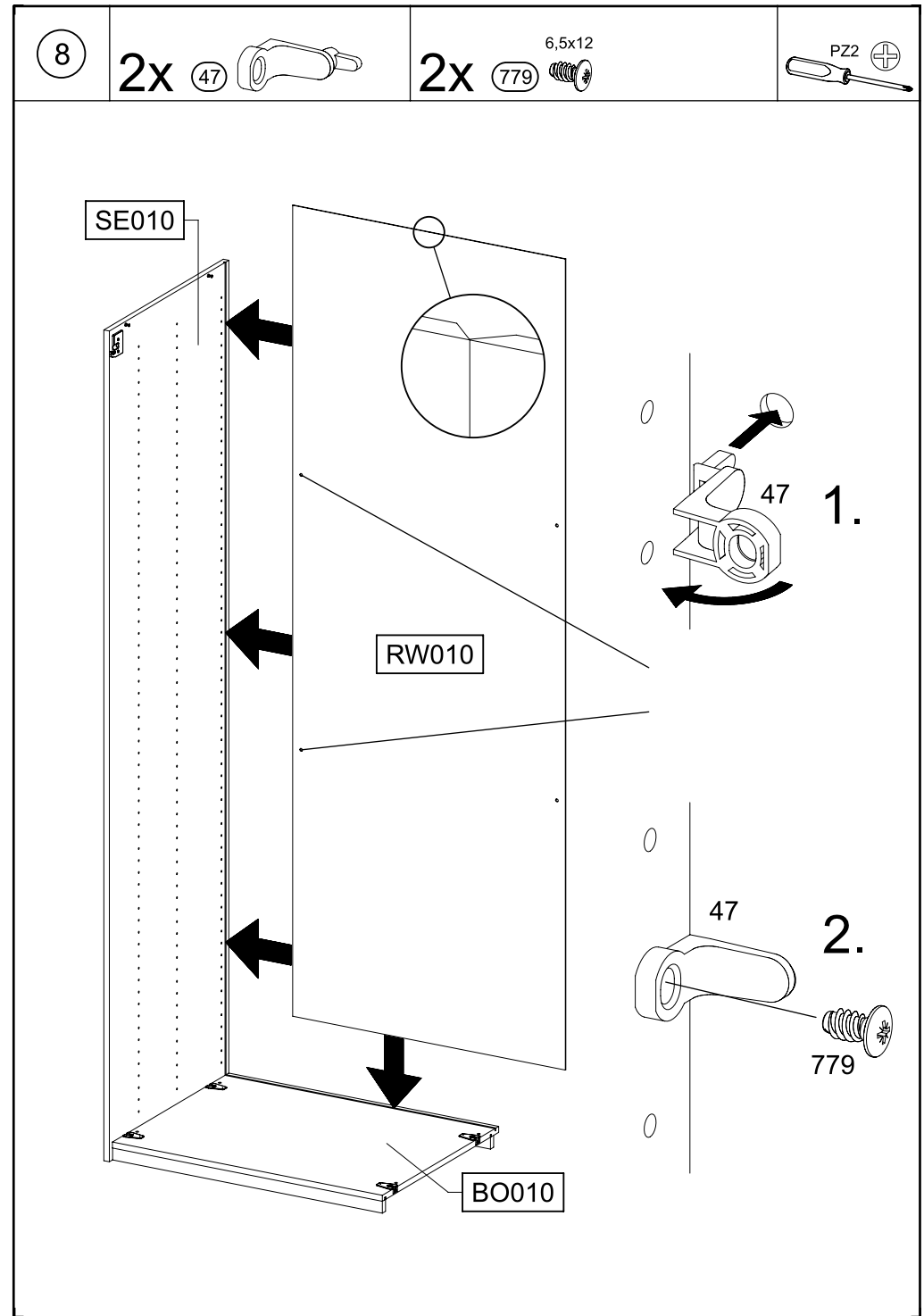
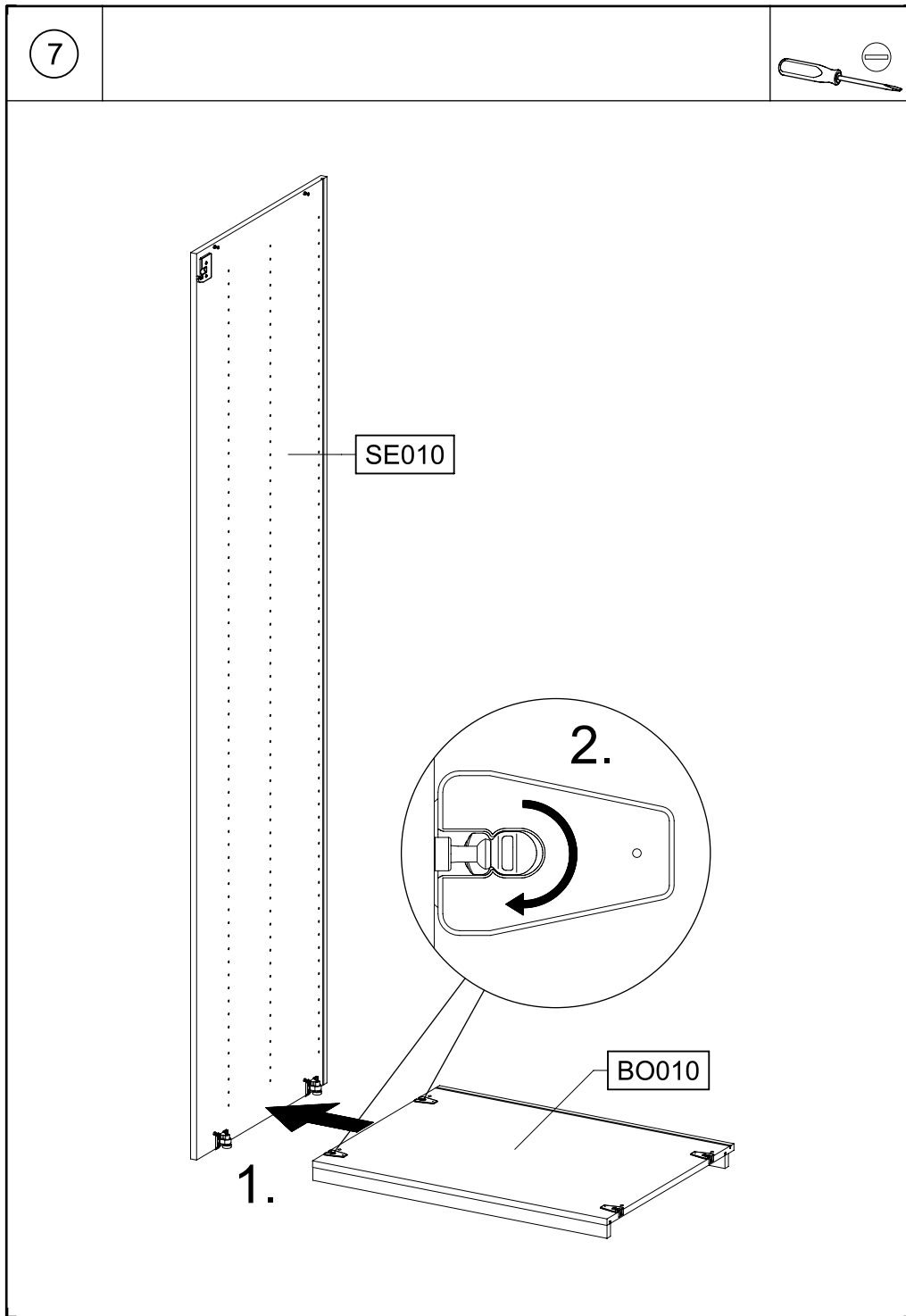

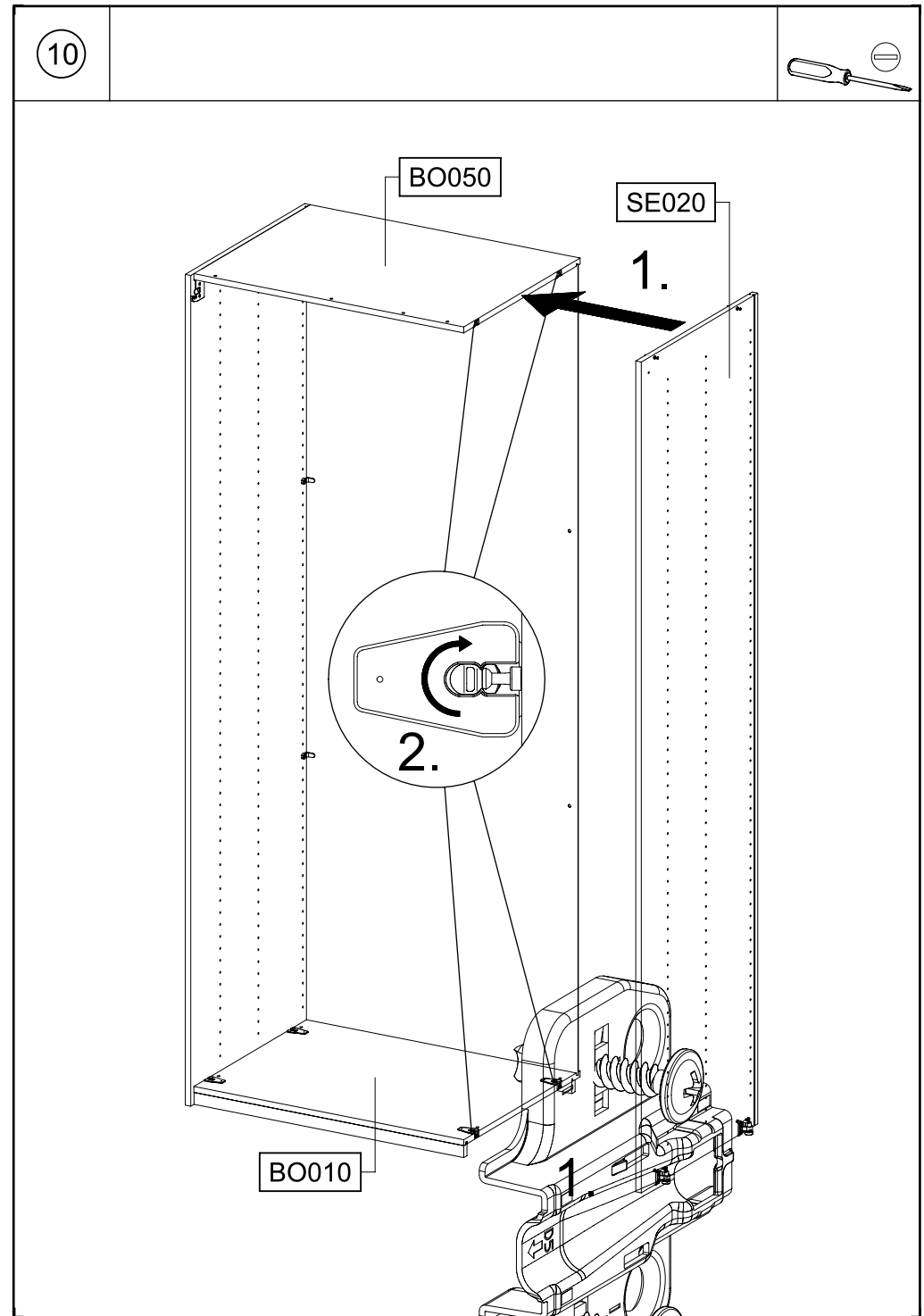
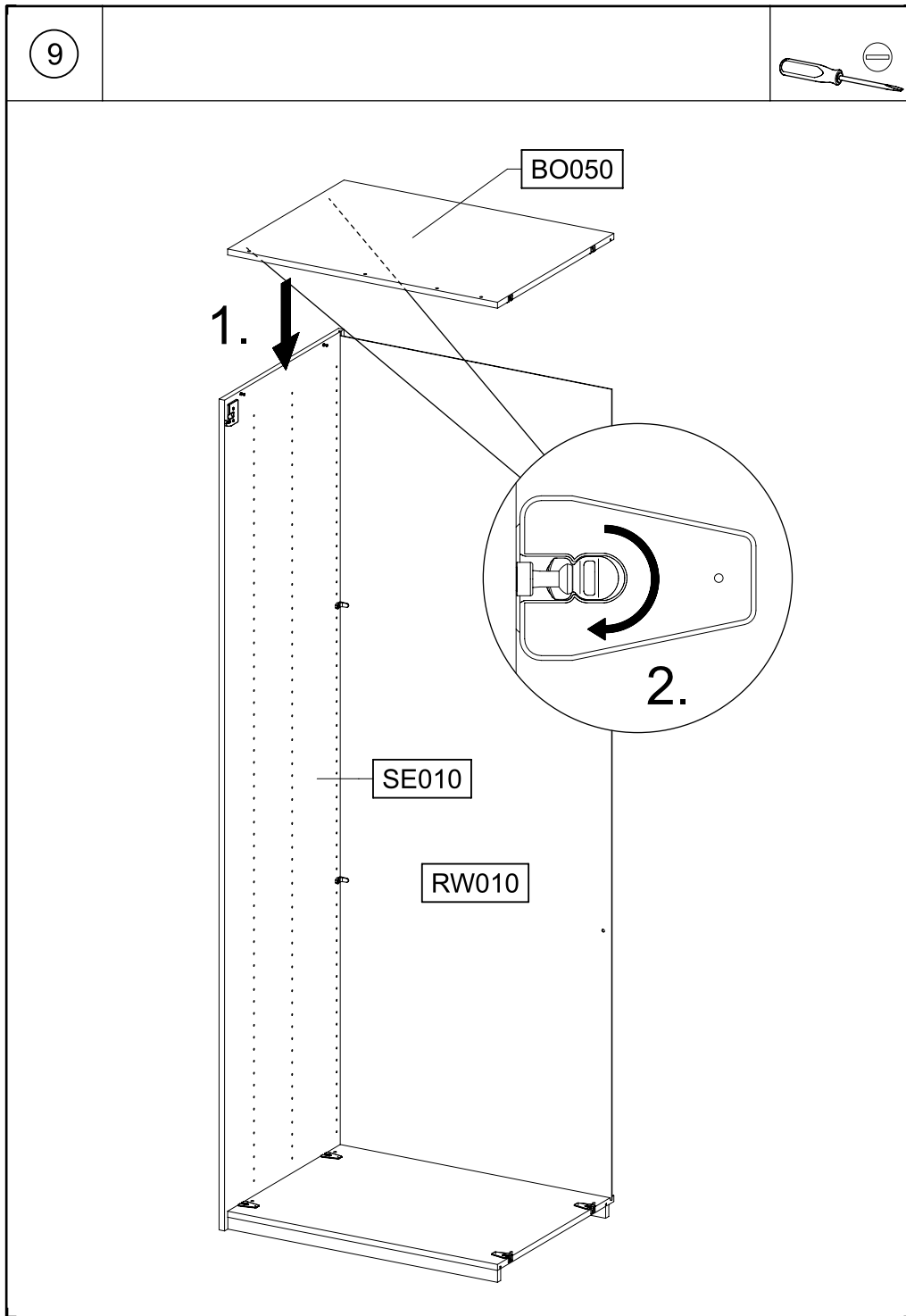

11

2x

47



2x

779

6,5x12



PZ2

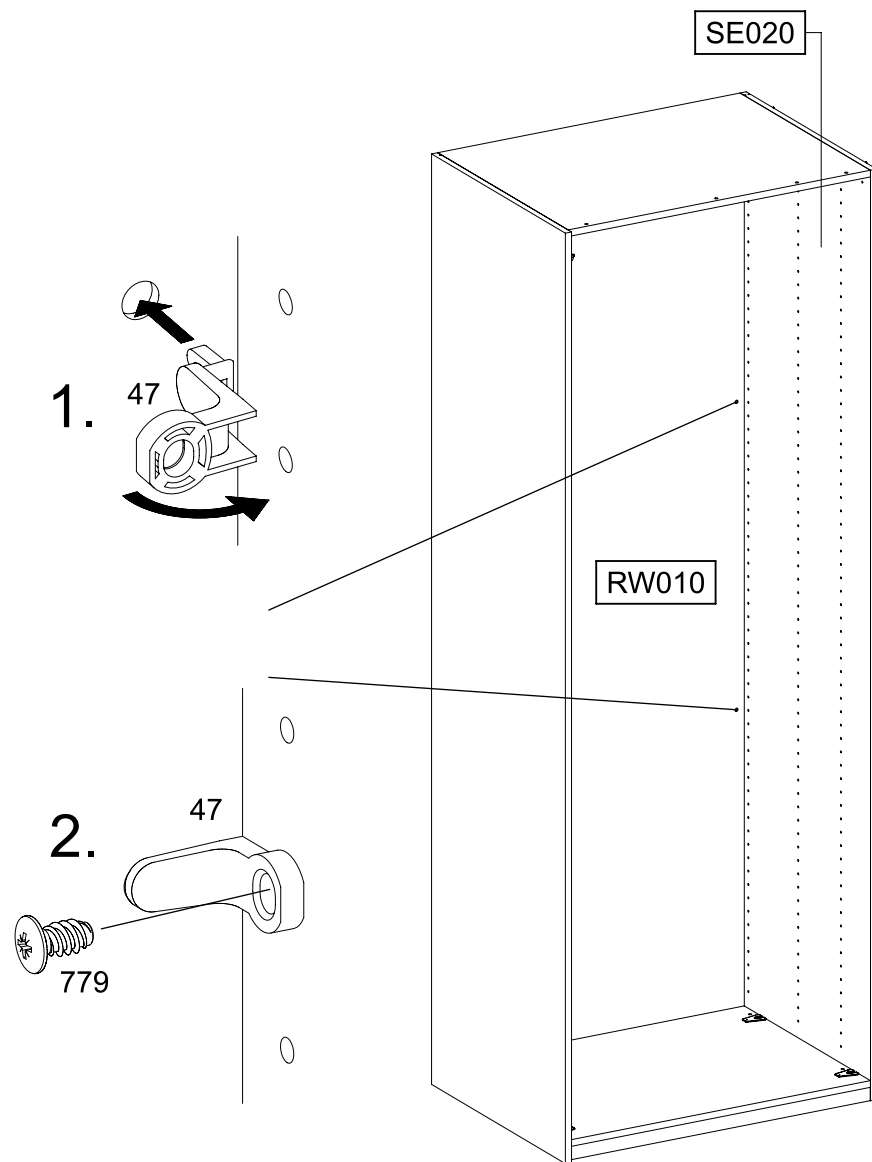

12

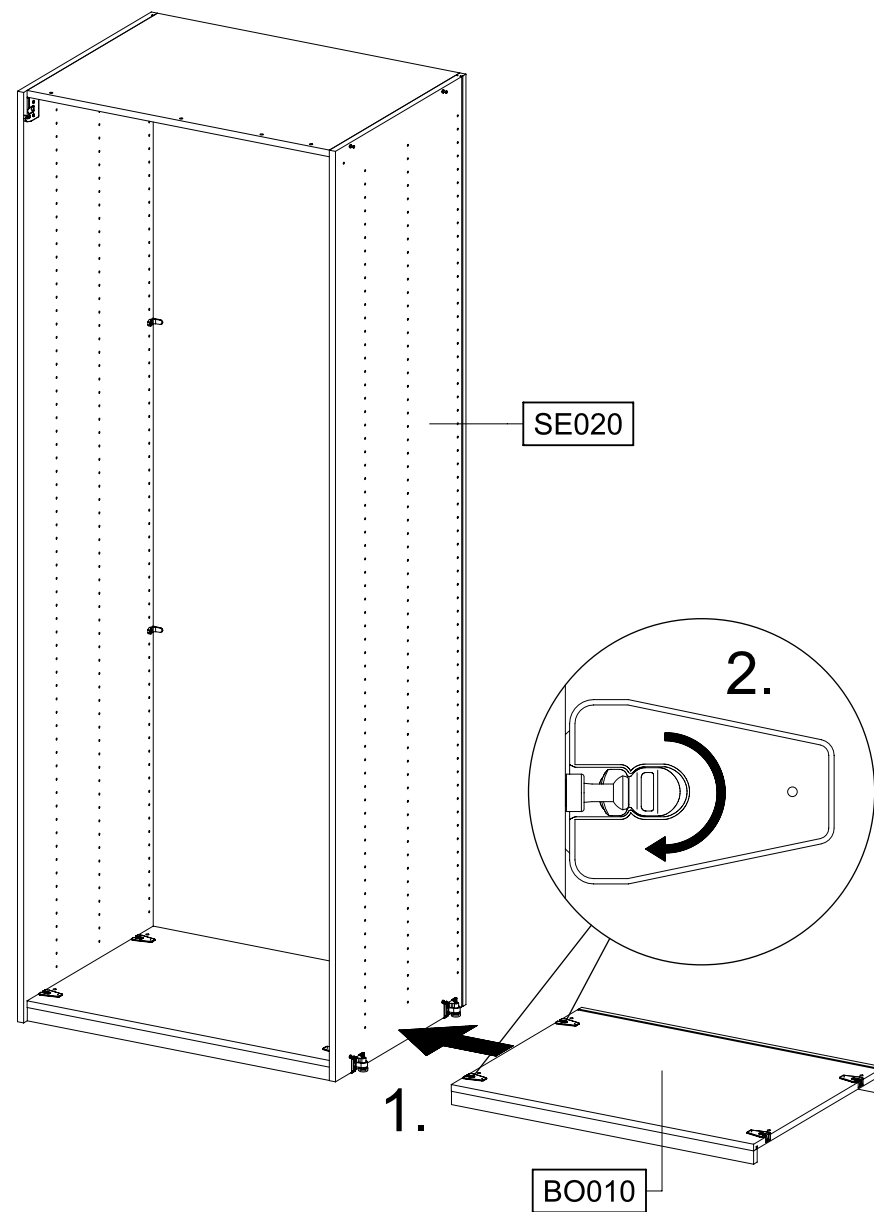
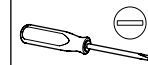

13

2x

47



2x

779

6,5x12

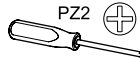

PZ2

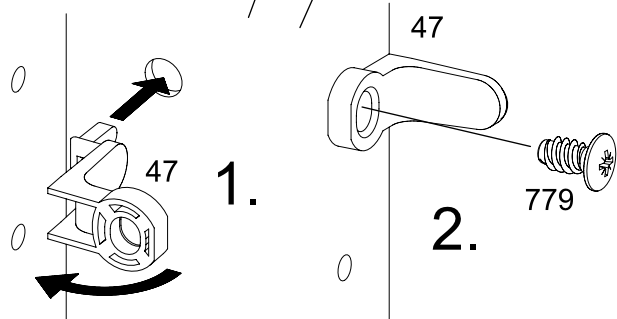
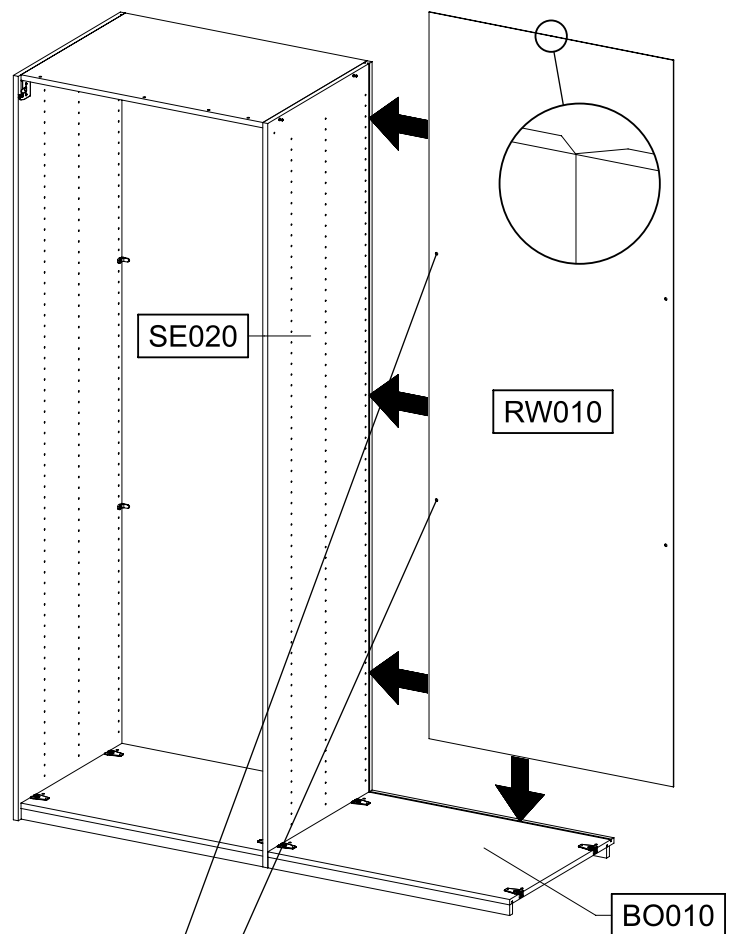

14

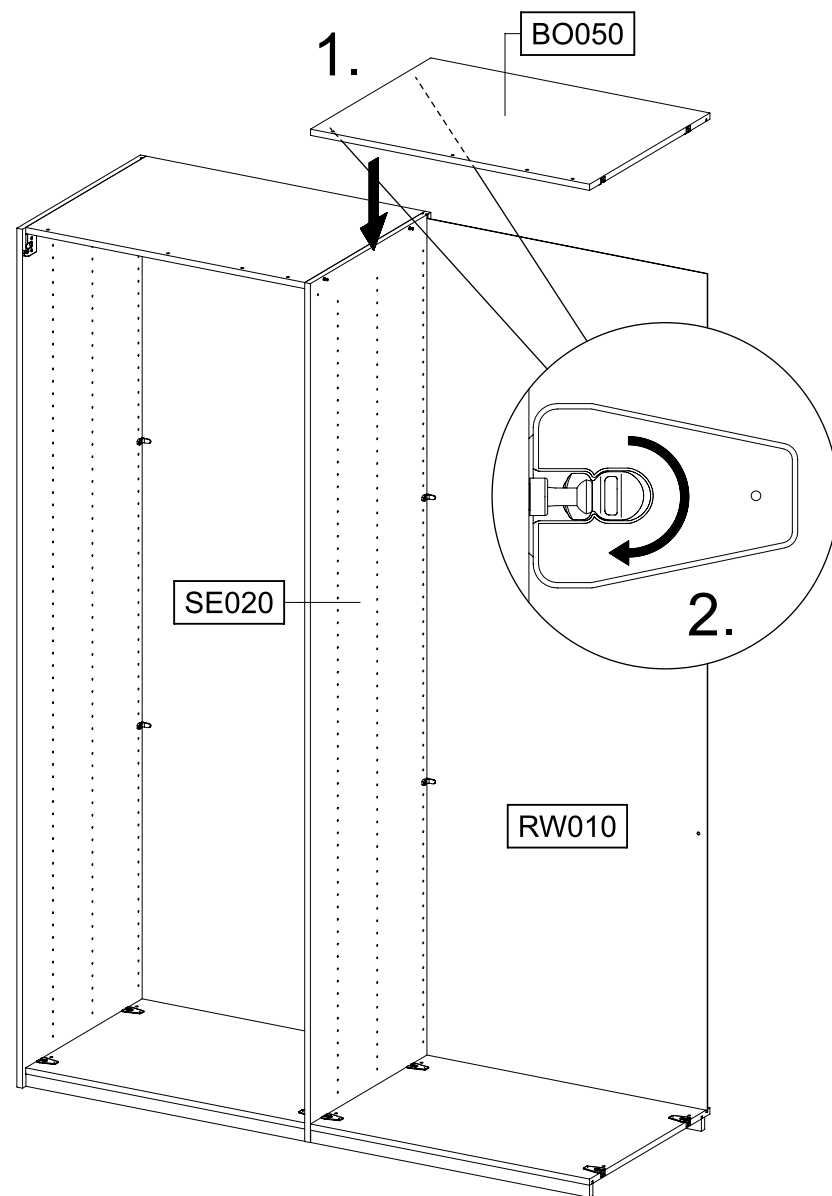
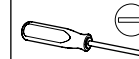

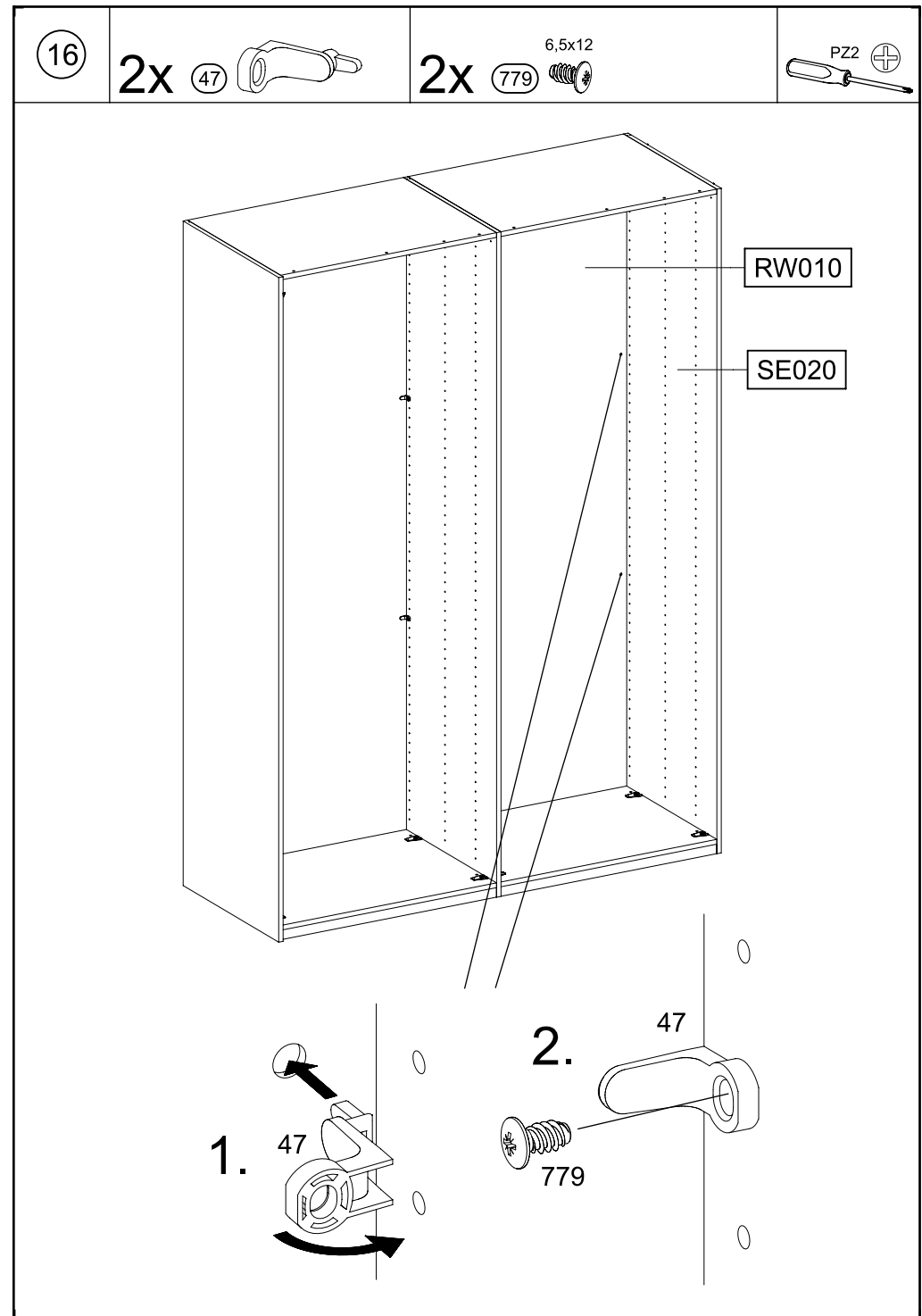
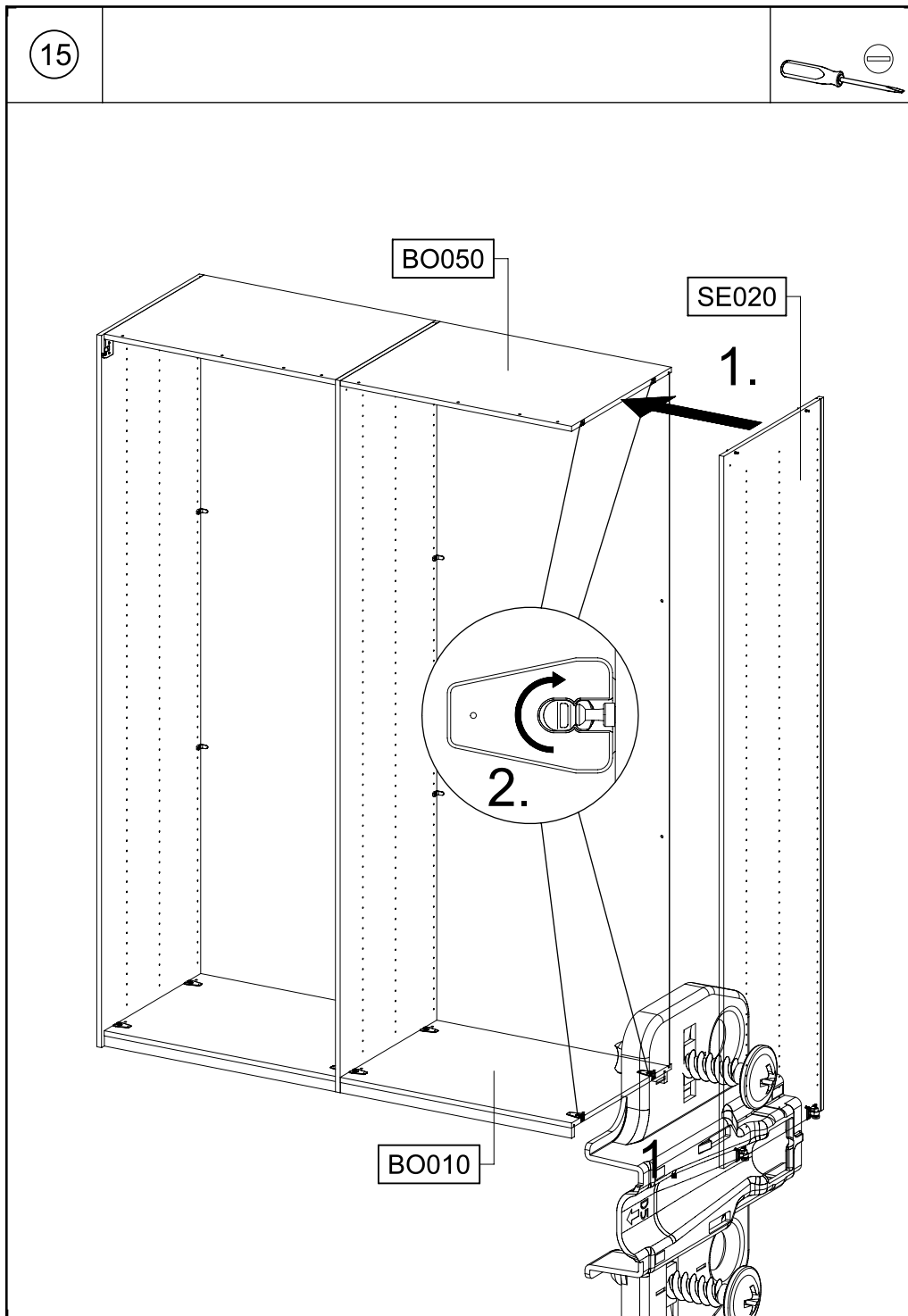

19

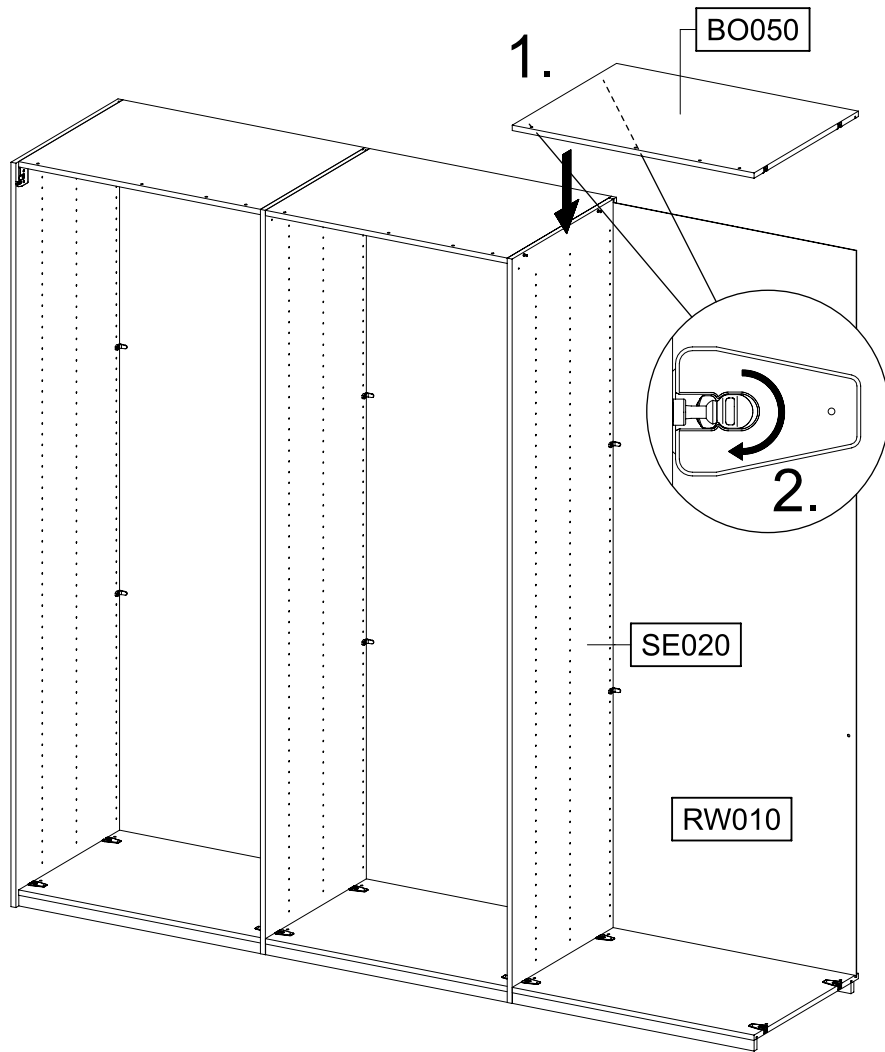
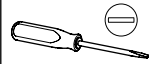

20

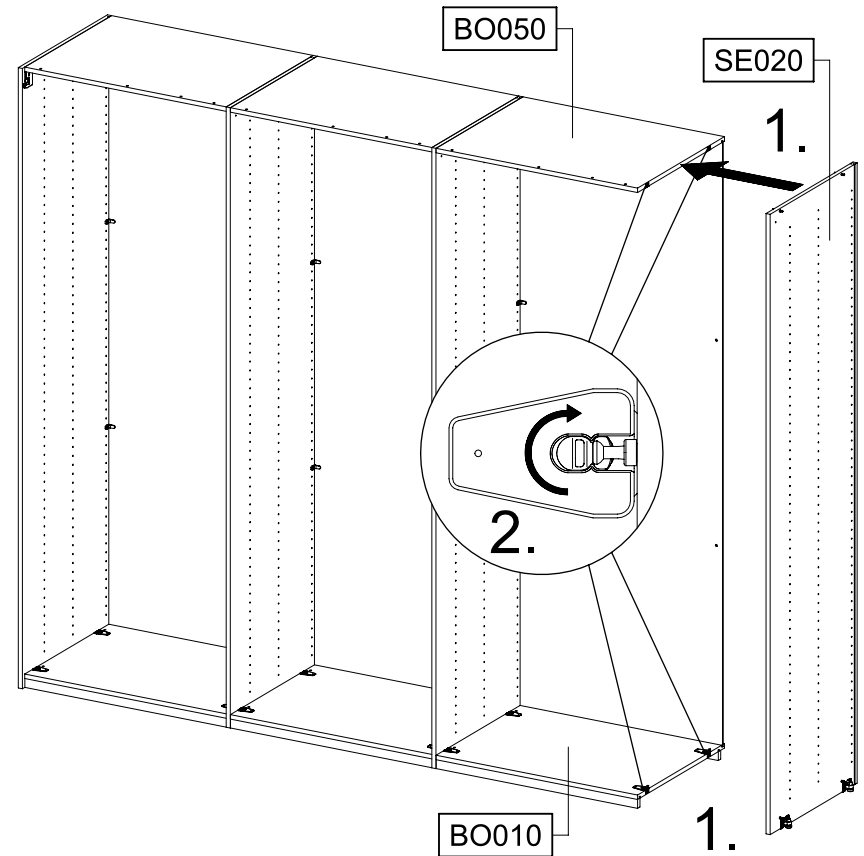
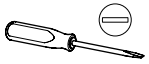

21

2x

47



2x

779

6,5x12



PZ2



RW010

SE020

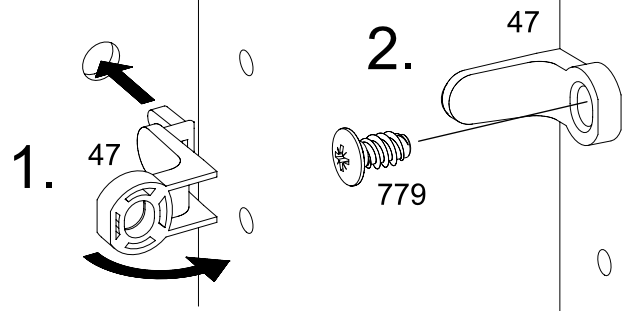
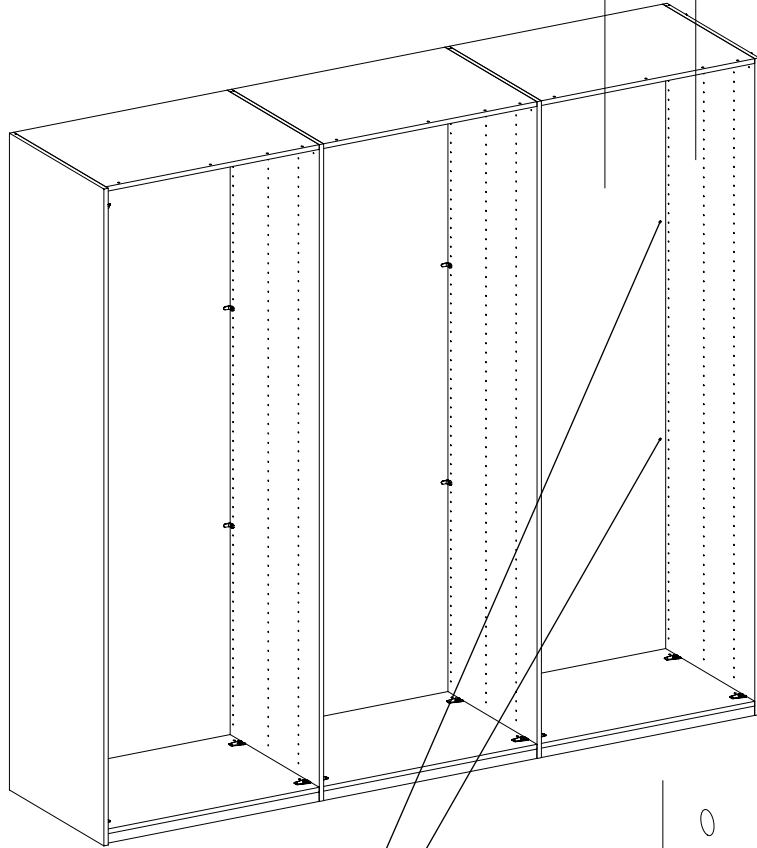

22

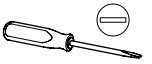

SE020

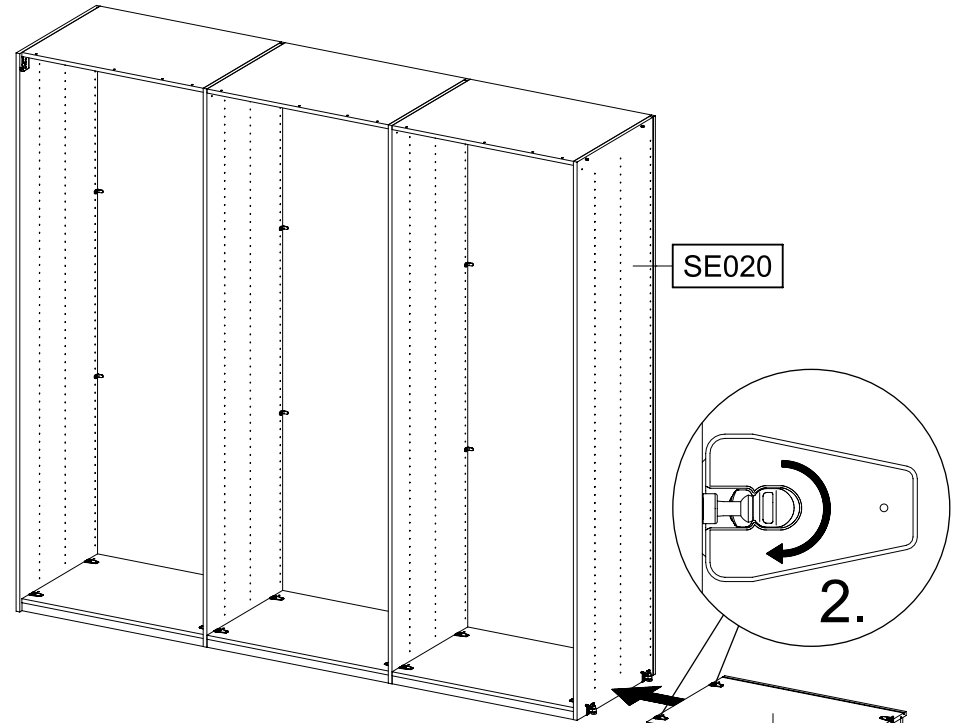

BO010

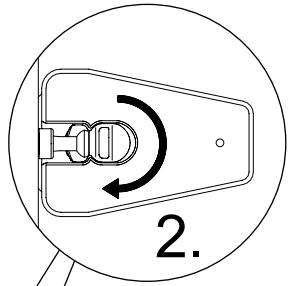

23

2x

47



2x

779

6,5x12



PZ2

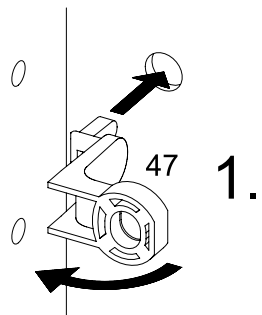
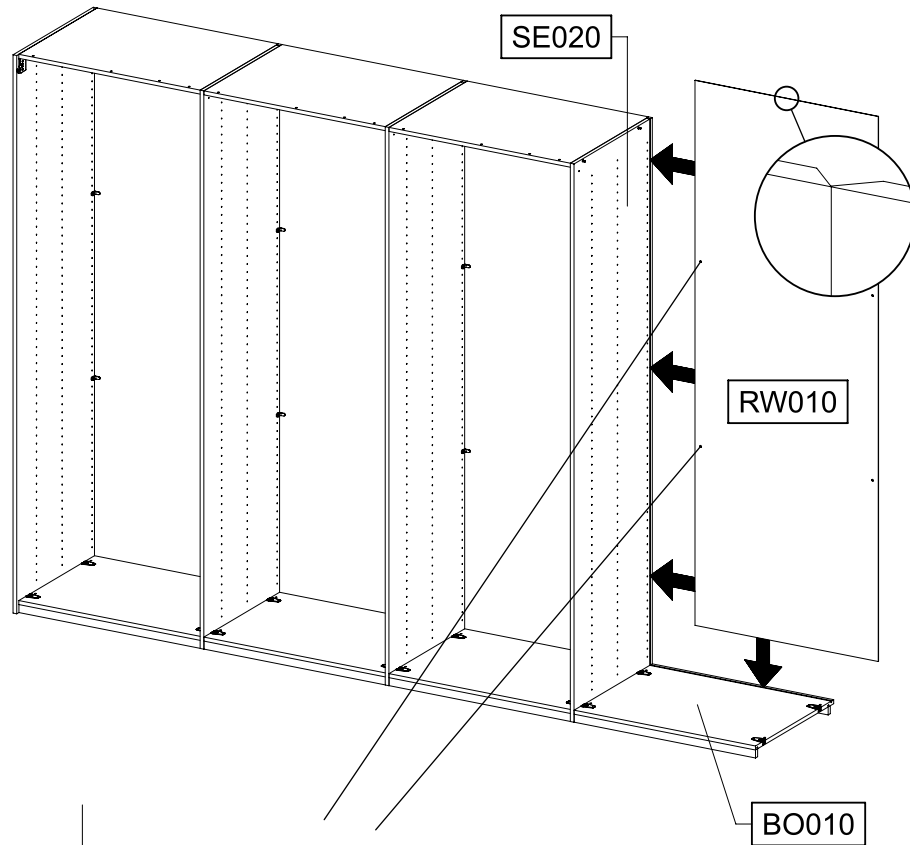

1.

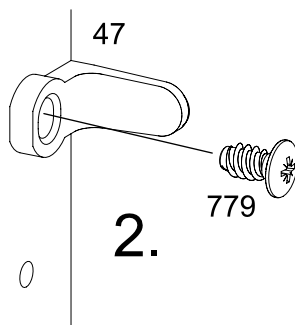

2.

24

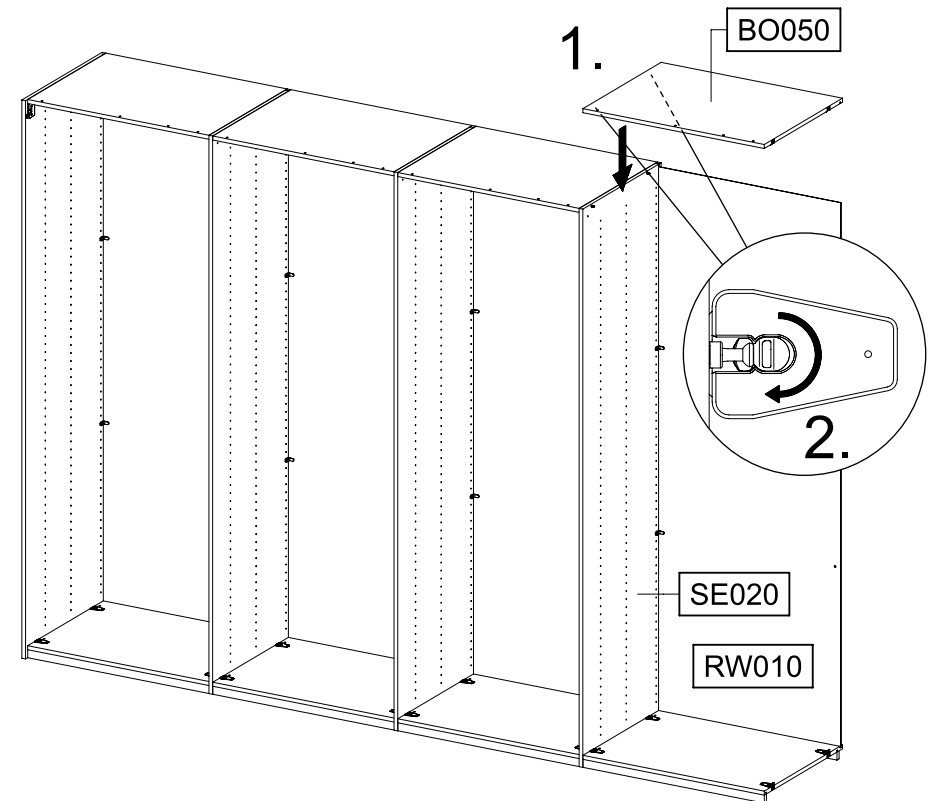
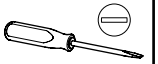

1.

BO050

2.

SE020

RW010

25

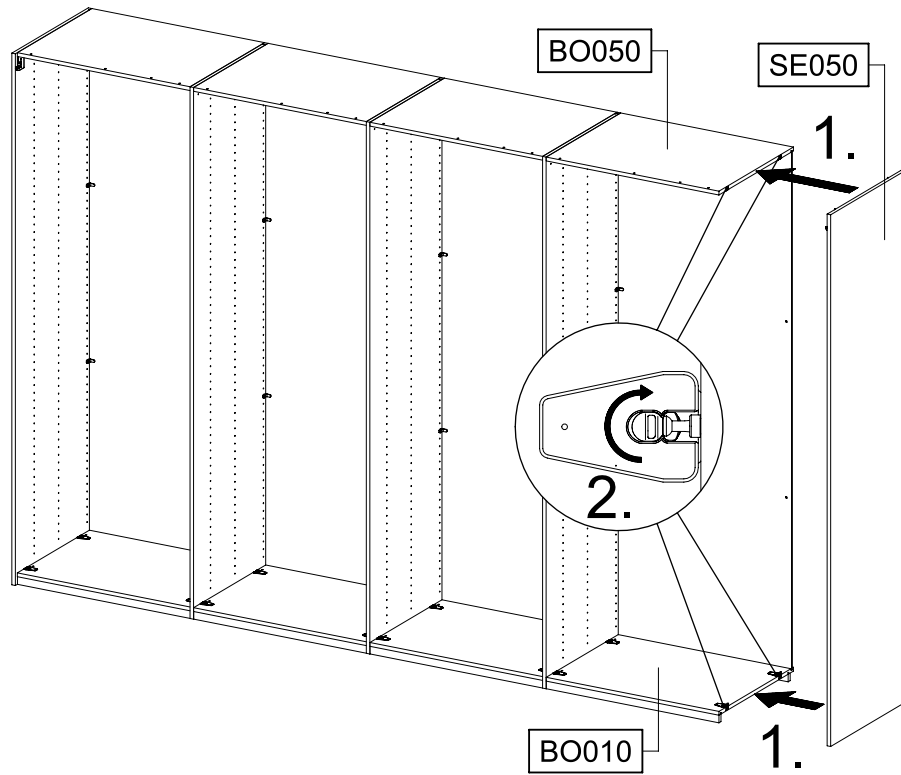
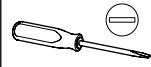

26

2x 47



2x 779

6,5x12

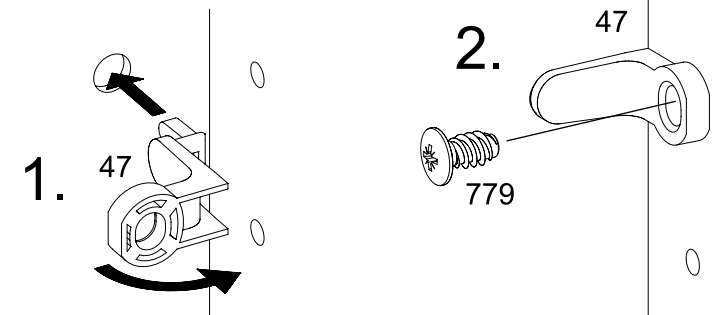
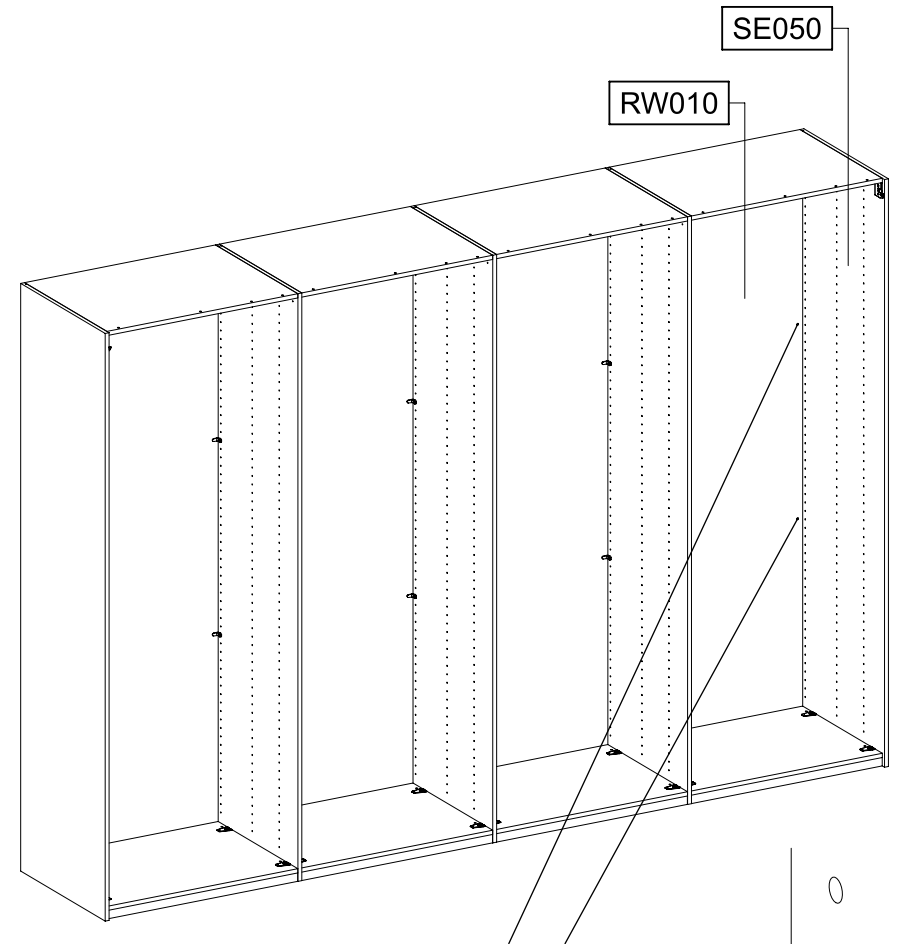
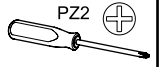

27

1x

133

31,8x15x8

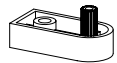

1x

205

3,5x15



PZ2

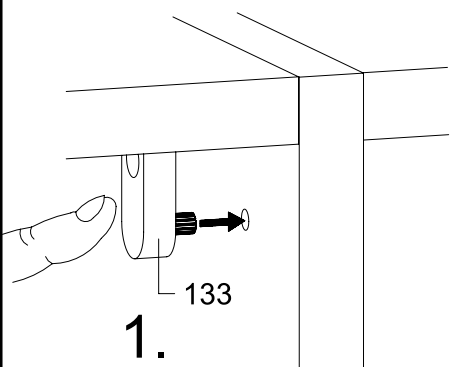
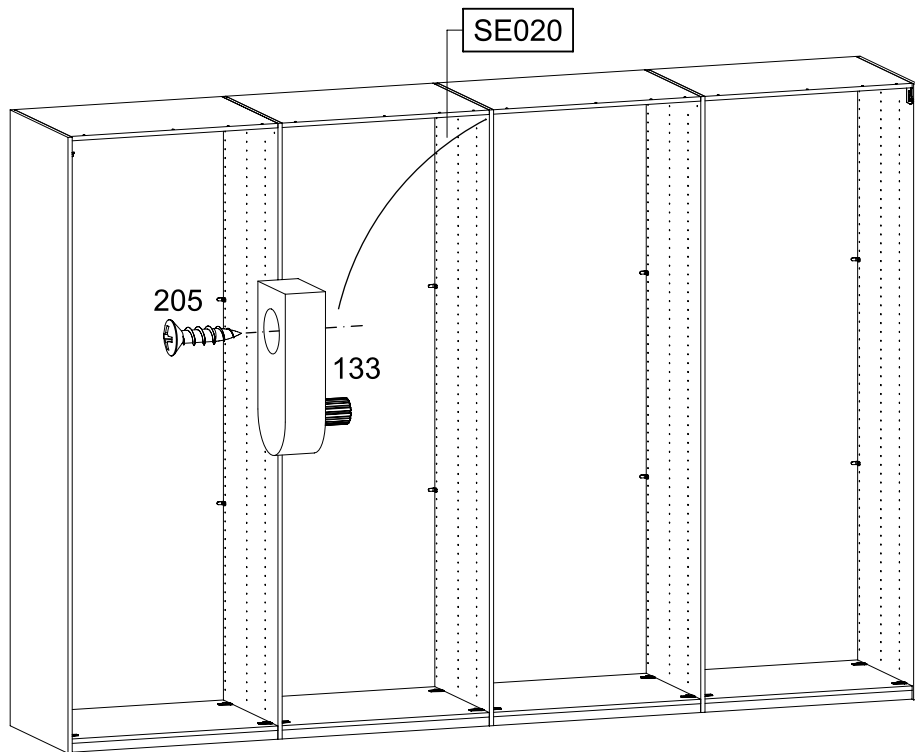

1.

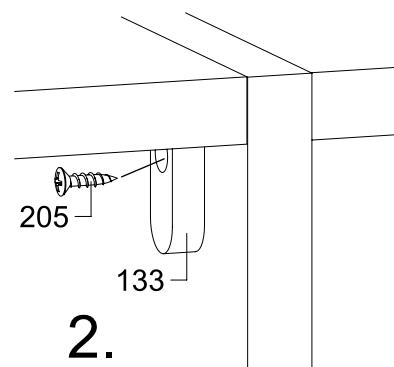

2.

28

16x

1089

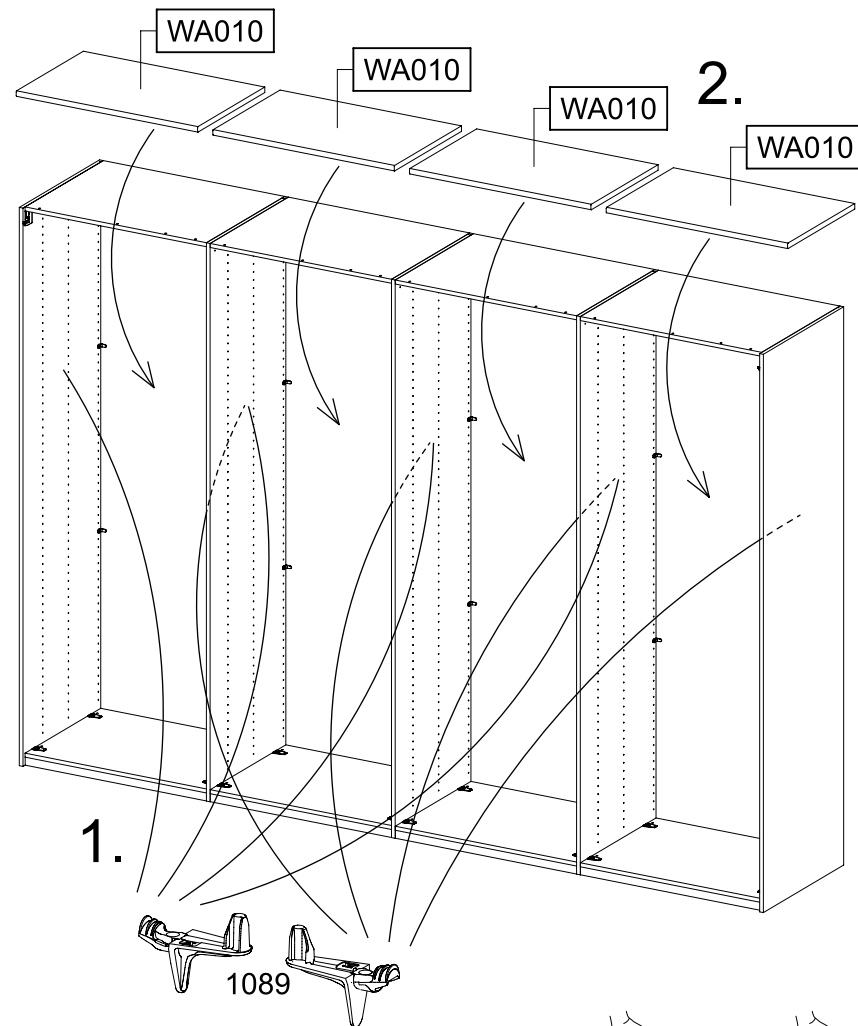

1.

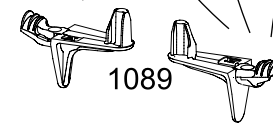

1089

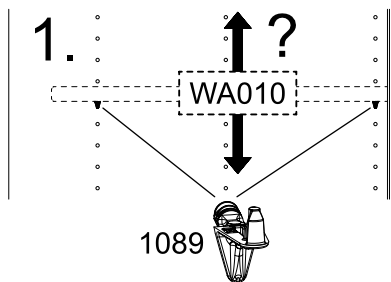

1.

1089

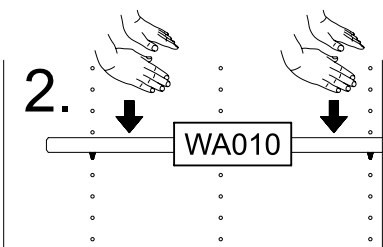

2.

2.

WA010

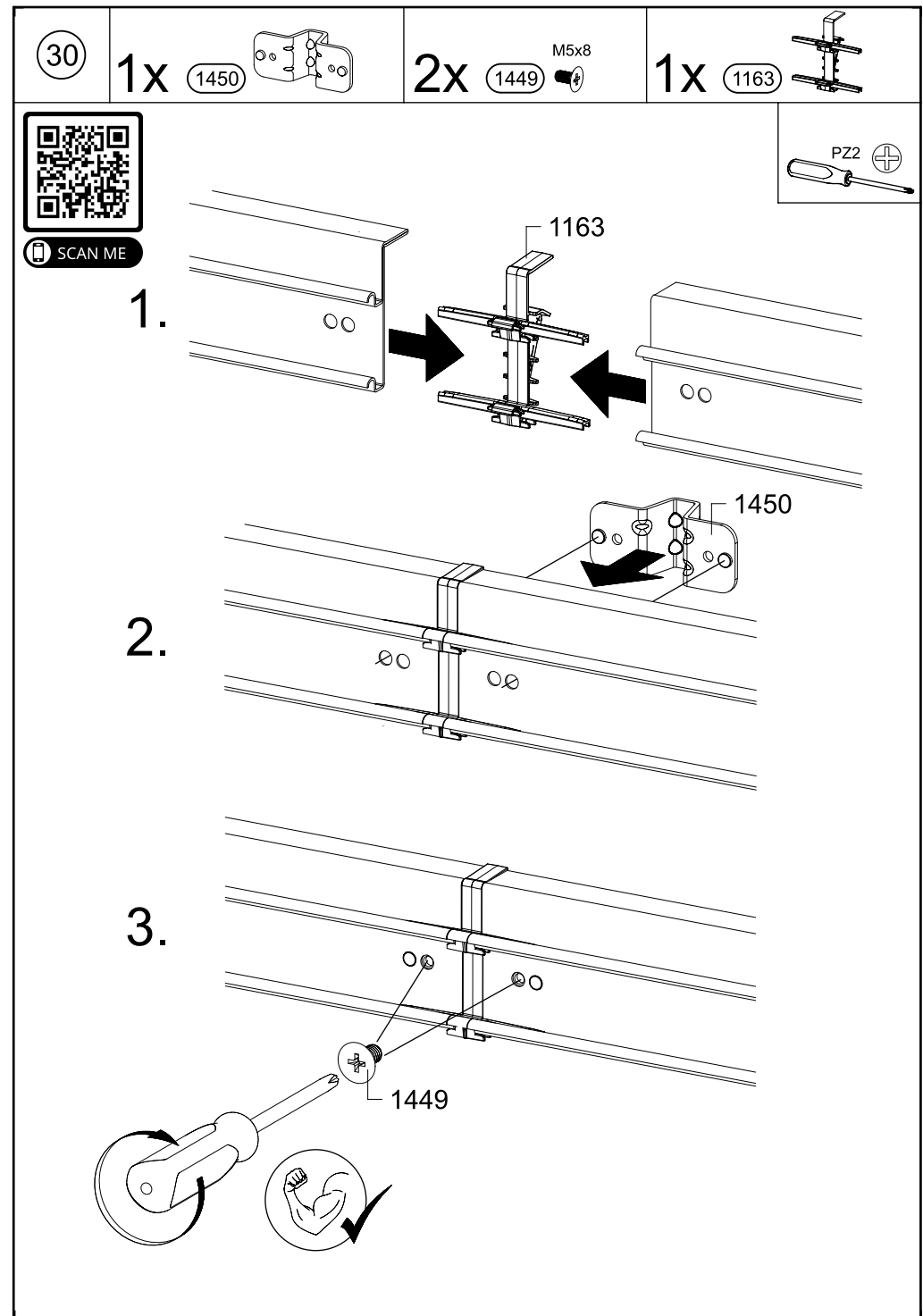
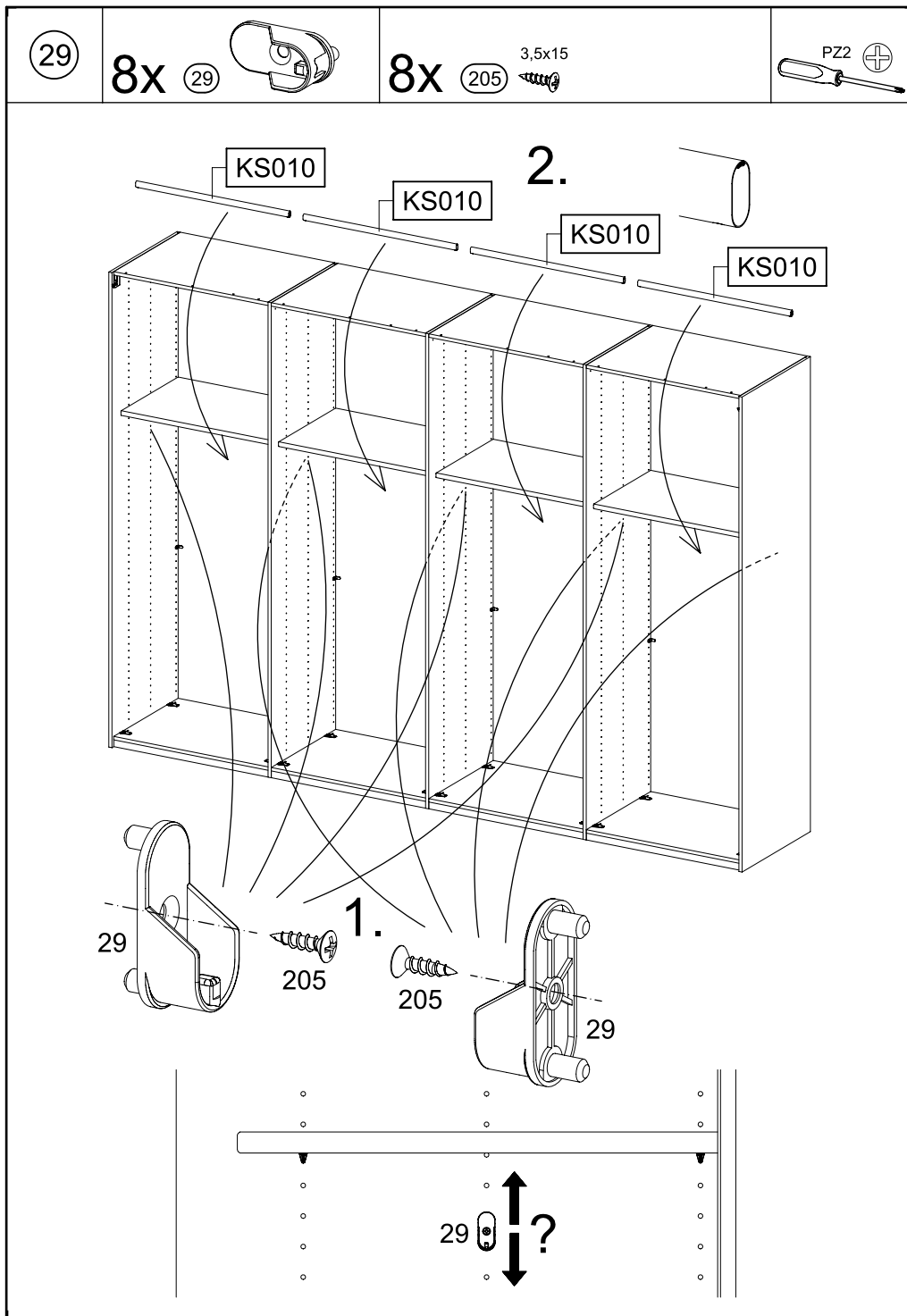

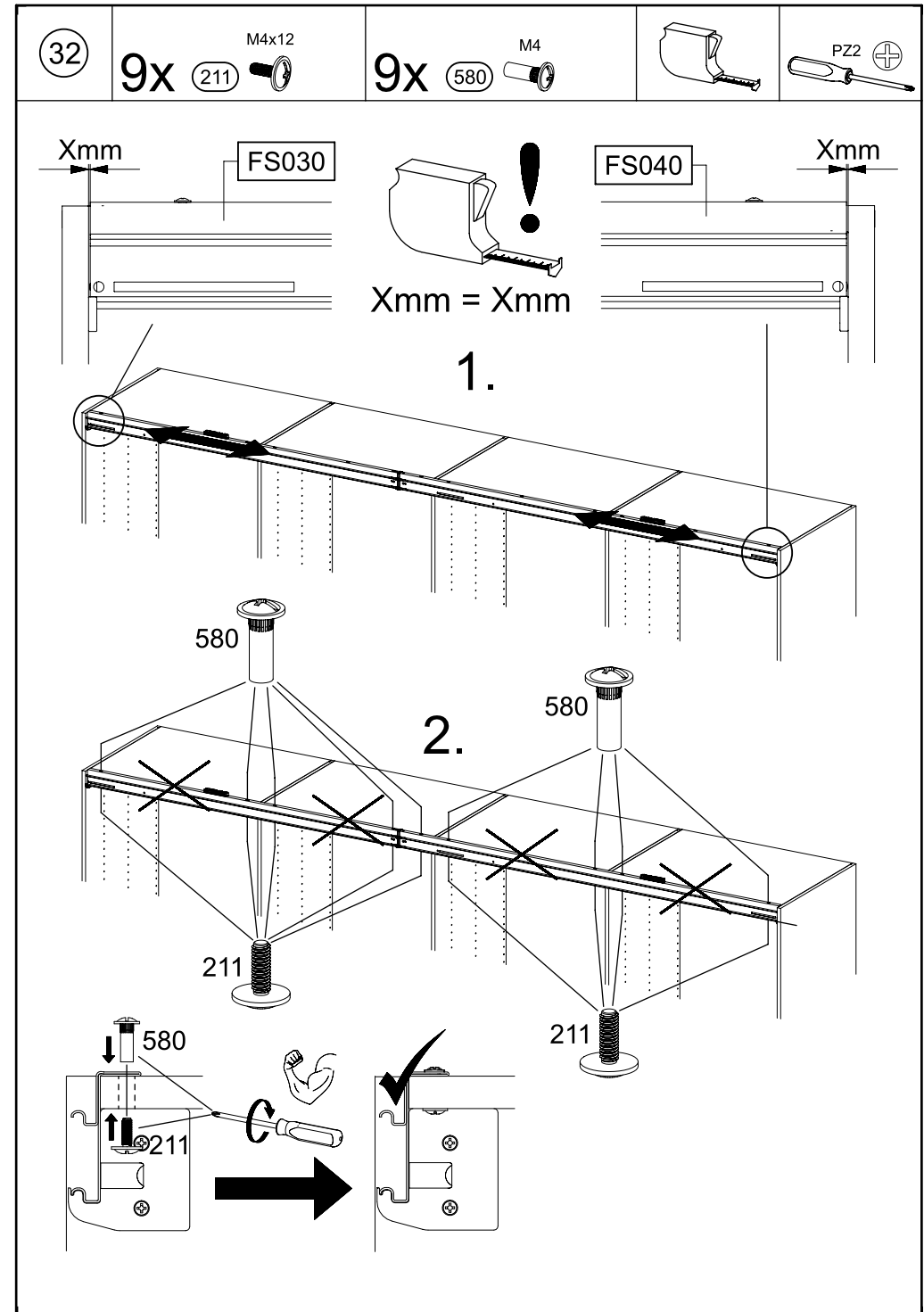
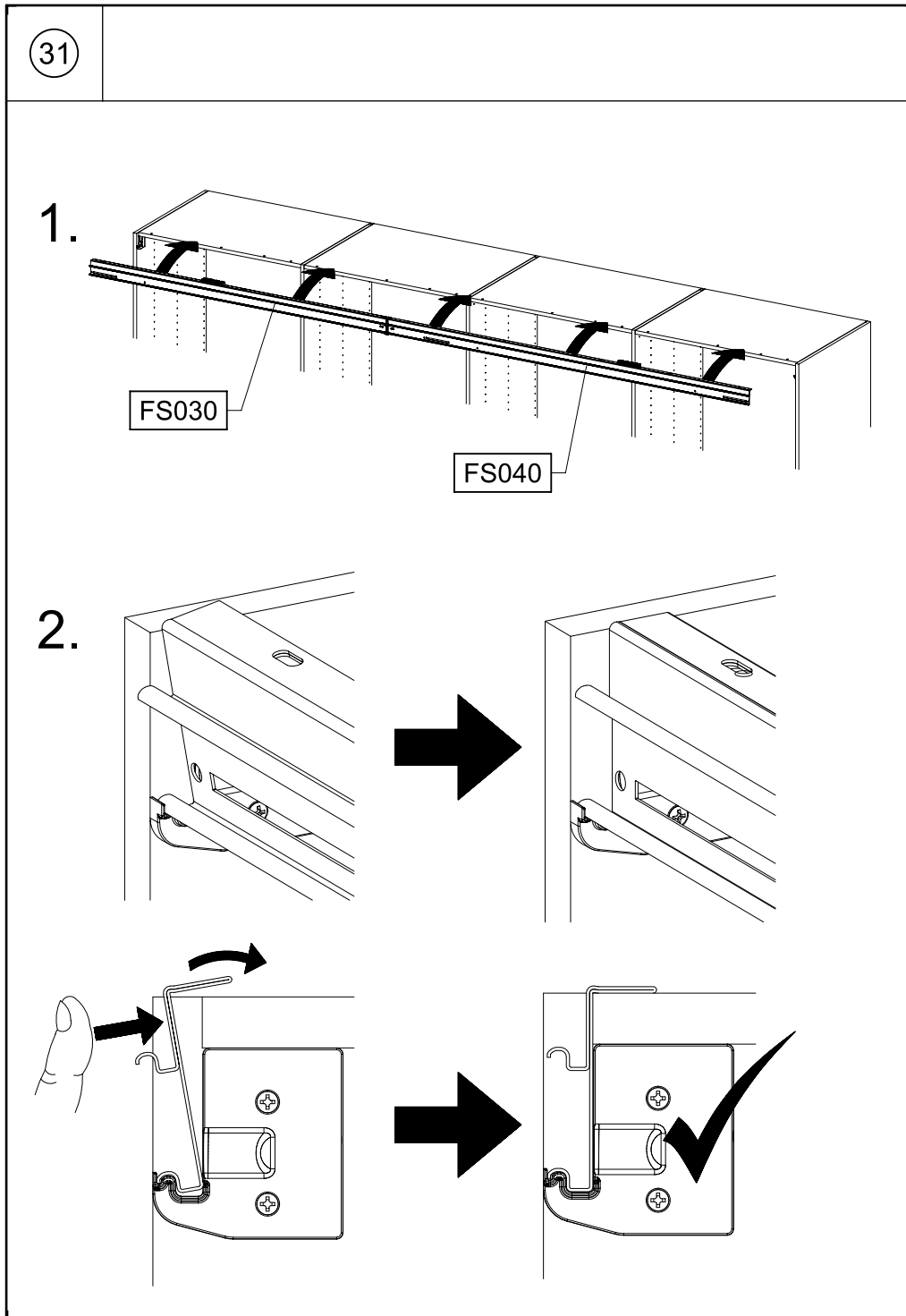

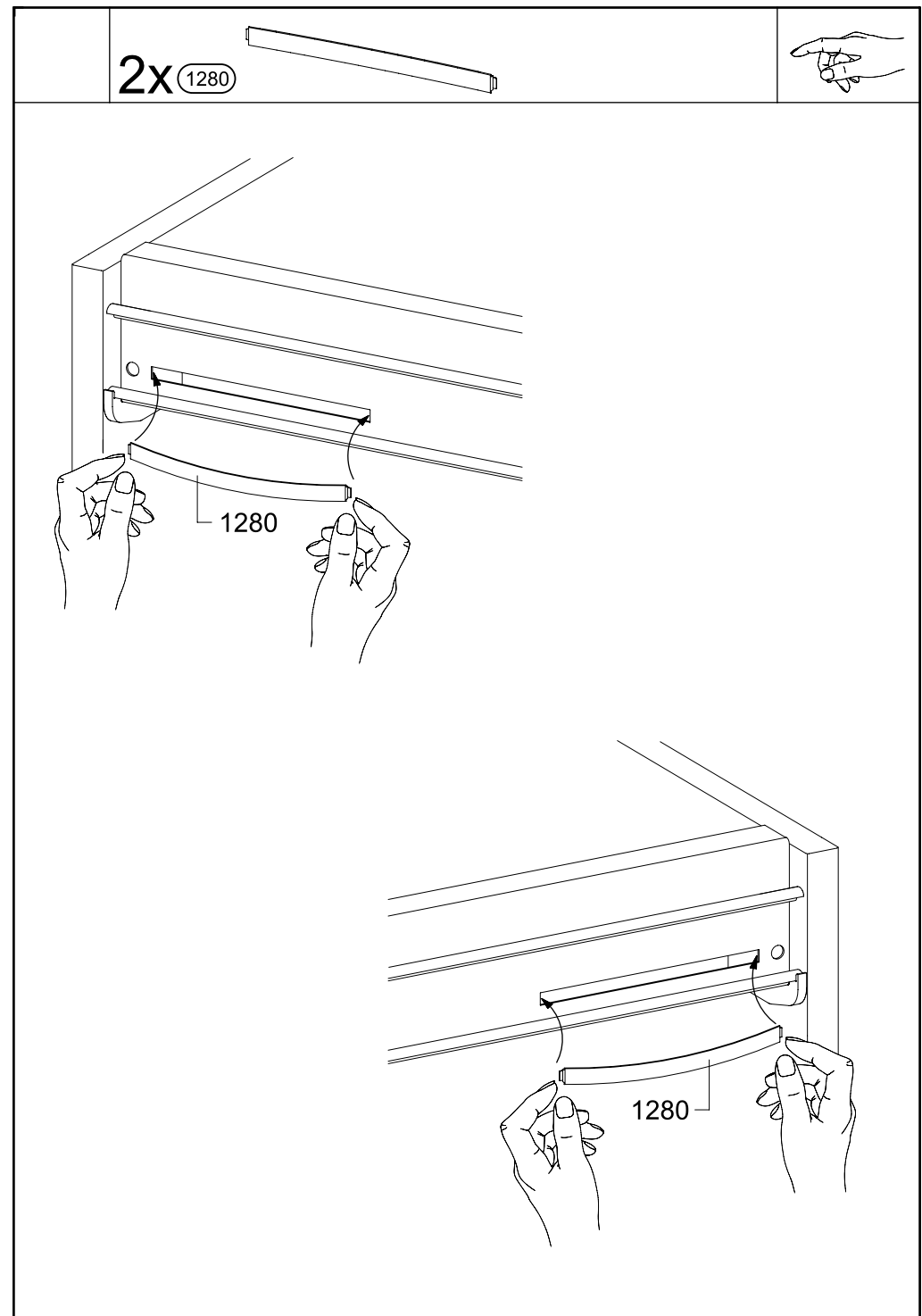
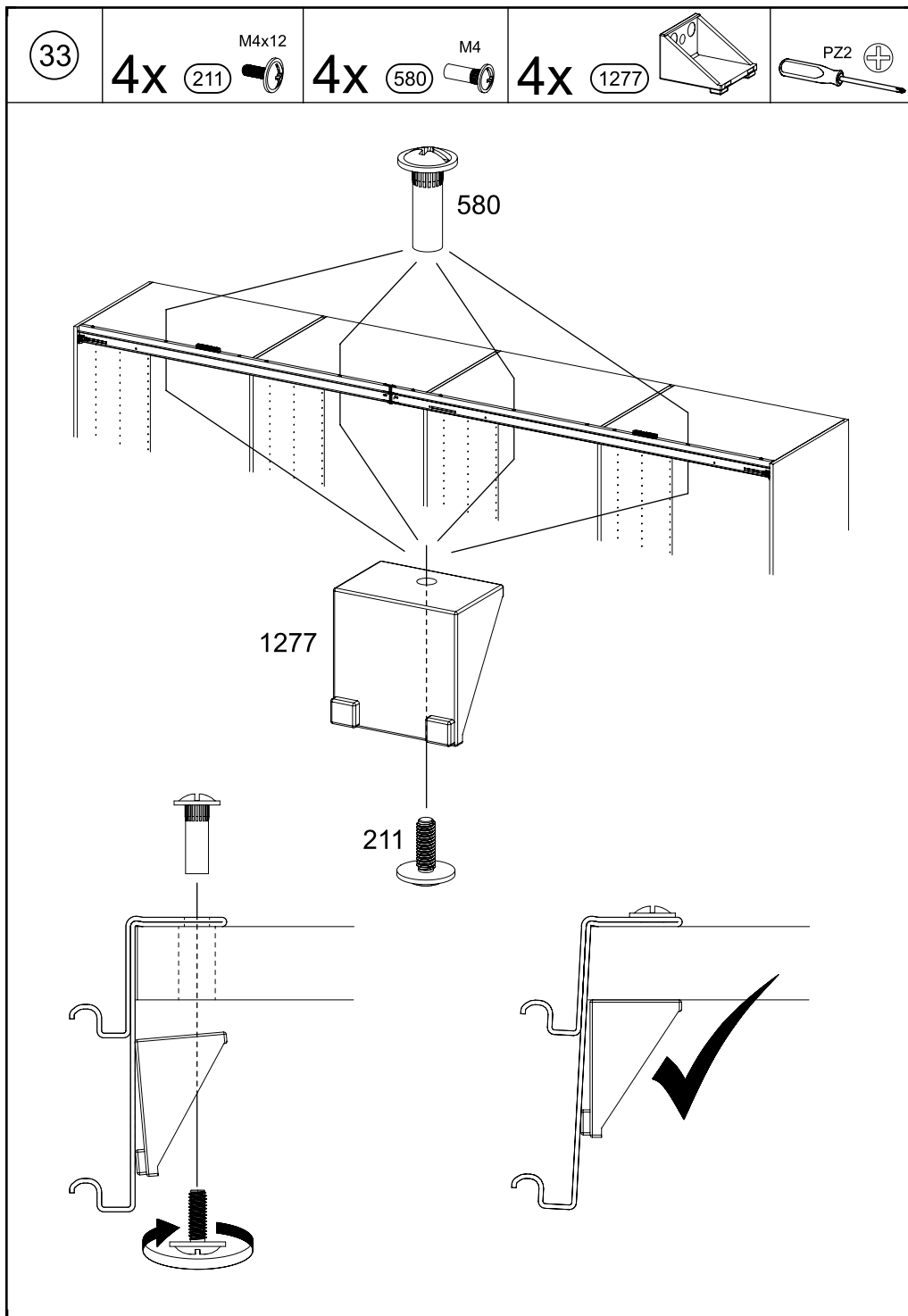

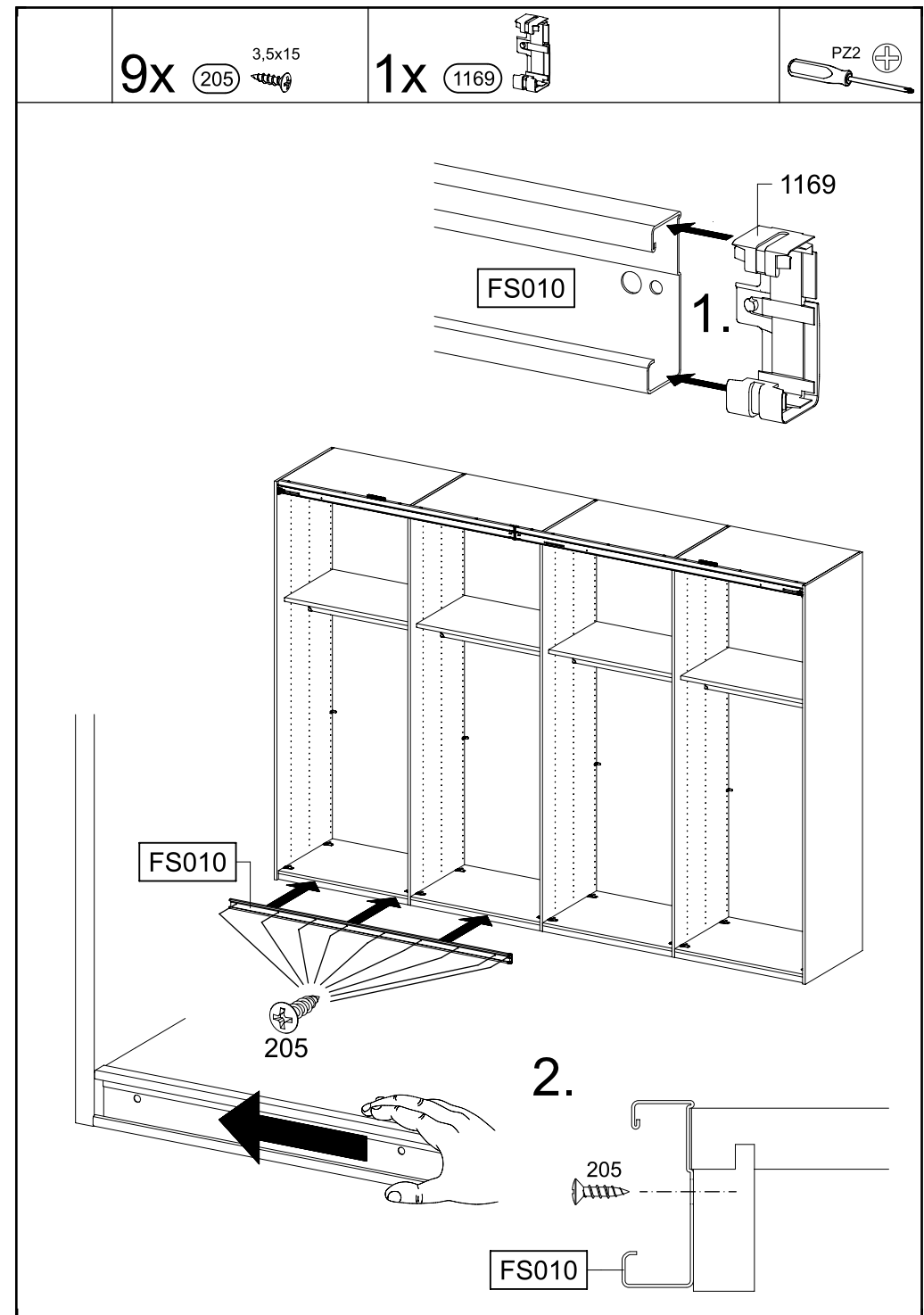
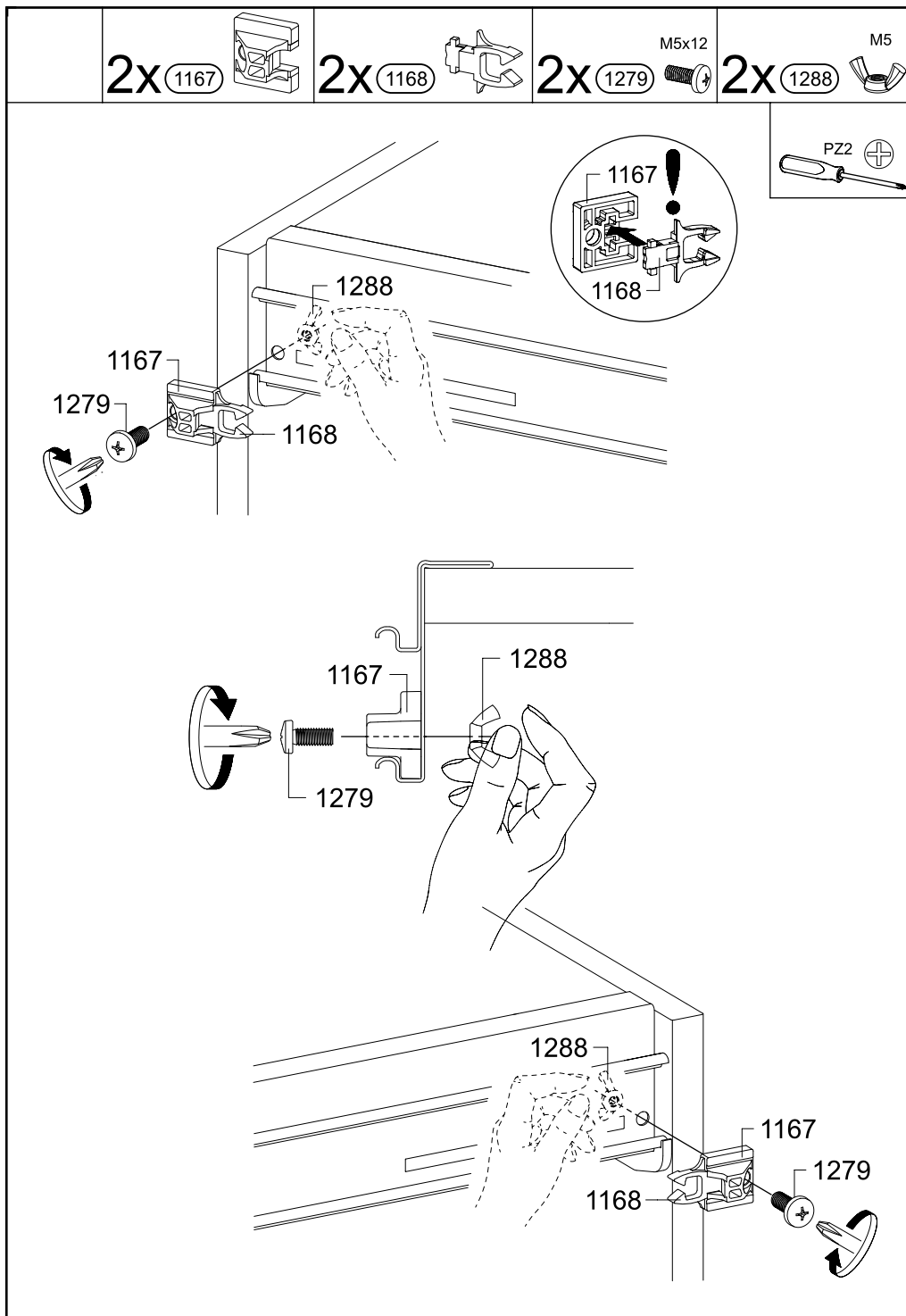

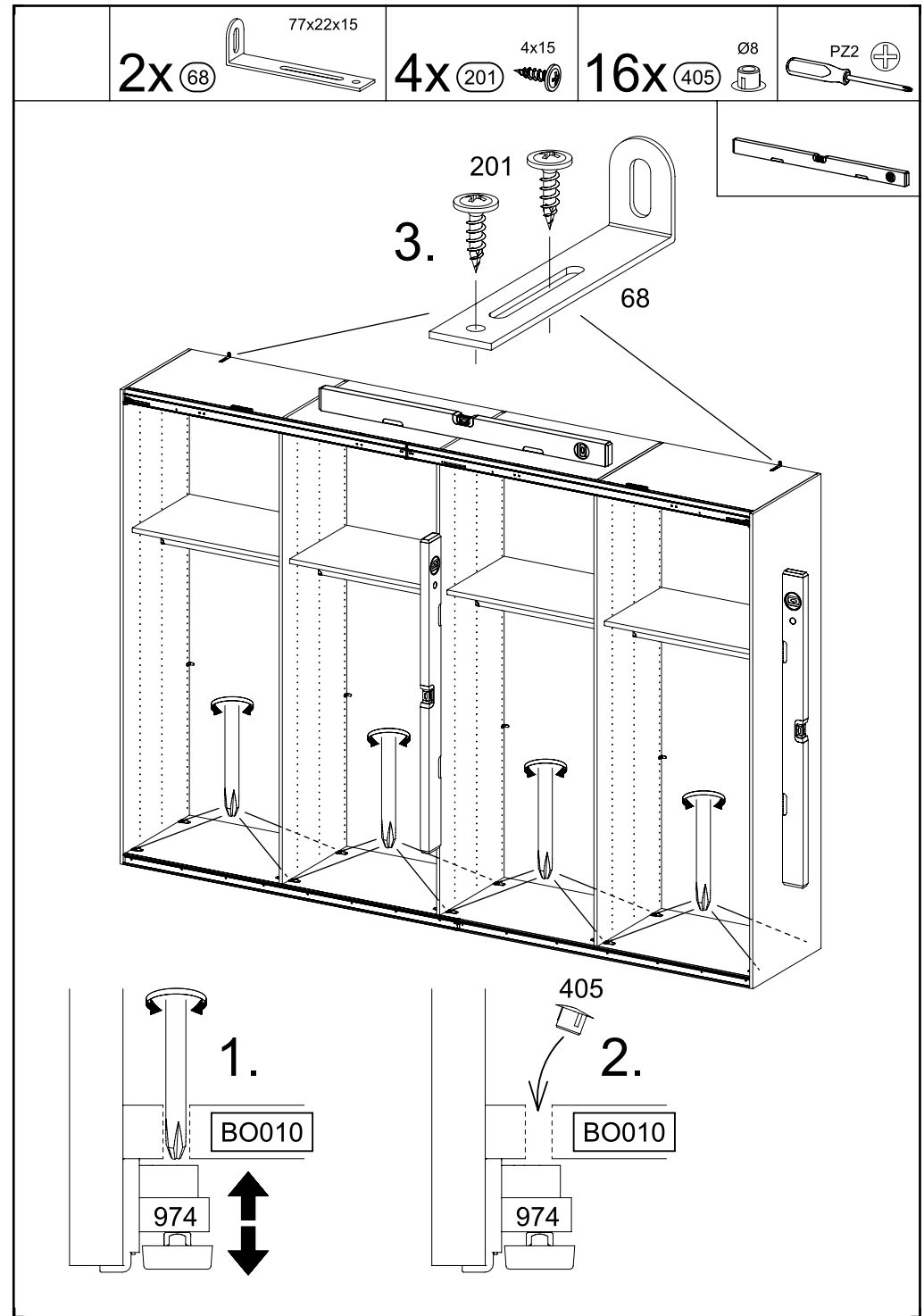
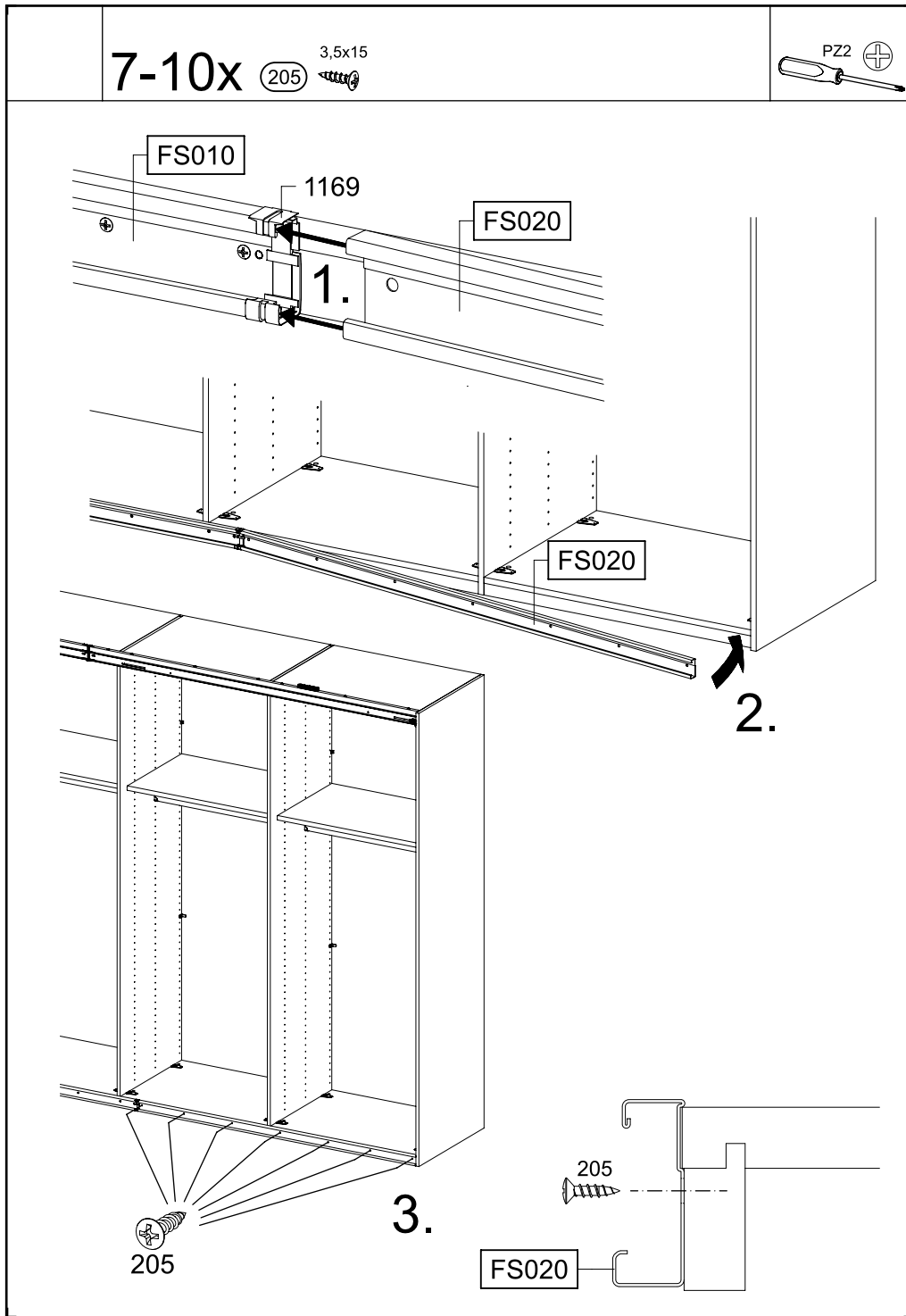



8x   Ø88x   Ø5

← 400 cm →

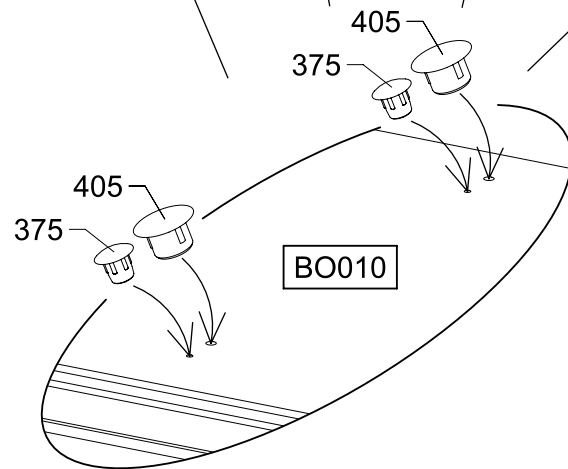
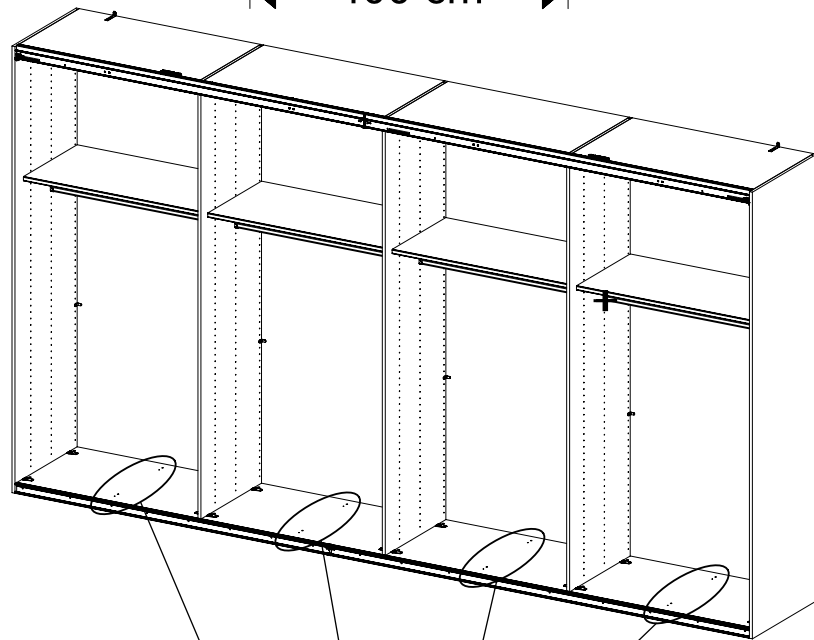
16x  PZ2 